

Odin

AUDIOSYSTEMS BY DAP

MANUAL

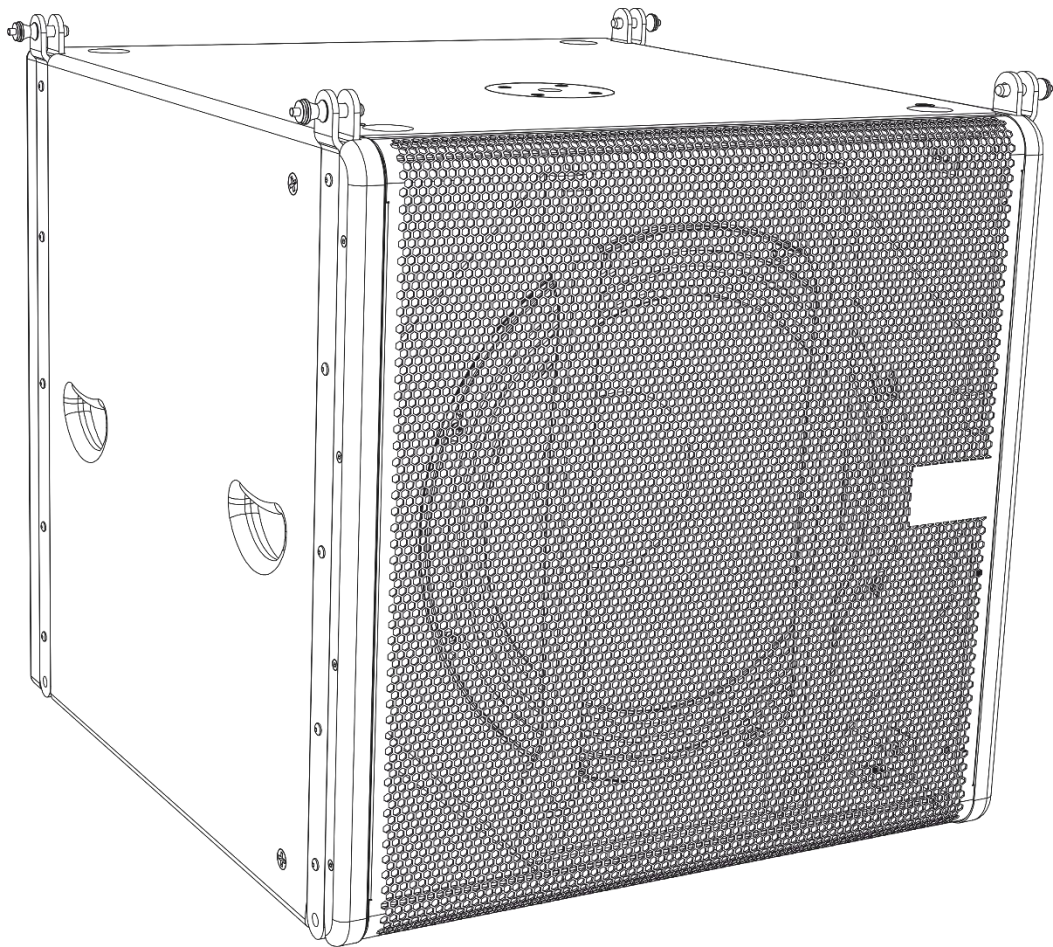

ENGLISH

Odin S-18A Line Array Sub

V3

Ordercode: D3901

Table of contents

Warning	2
Safety Instructions	2
Connection with the mains.....	4
Return Procedure	4
Claims.....	4
Description of the device	5
Overview	5
Backside	6
Installation	7
Connection Example	7
Set Up and Operation	8
Preset Selector	8
Presets	8
Connection Cables	8
How to Make a Data Cable	9
Maintenance	9
Troubleshooting	9
Product Specifications	10

Warning



**For your own safety, please read this user manual carefully
before your initial start-up!**



Unpacking Instructions

Immediately upon receiving this product, carefully unpack the carton and check the contents to ensure that all parts are present, and have been received in good condition. Notify the dealer immediately and retain packing material for inspection if any parts appear damaged from shipping or the carton itself shows signs of mishandling. Save the carton and all packing materials. In the event that a fixture must be returned to the factory, it is important that the fixture be returned in the original factory box and packing.

Your shipment includes:

- Odin S-18A Line Array Sub
- Power cable **NOT** included
- Network cable **NOT** included
- User manual

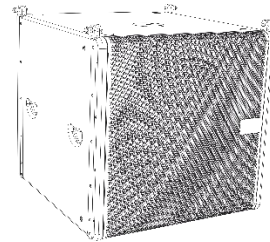

CAUTION!
Keep this device away from rain and moisture!
Unplug mains lead before opening the housing!



Safety Instructions

Every person involved with the installation, operation and maintenance of this system has to:

- be qualified
- follow the instructions of this manual



CAUTION! Be careful with your operations.
**With a dangerous voltage you can suffer
a dangerous electric shock when touching the wires!**



Before you initial start-up, please make sure that there is no damage caused by transportation.

Should there be any, consult your dealer and do not use the system.

To maintain perfect condition and to ensure a safe operation, it is absolutely necessary for the user to follow the safety instructions and warning notes written in this manual.

Please consider that damages caused by manual modifications to the system are not subject to warranty.

This system contains no user-serviceable parts. Refer servicing to qualified technicians only.

IMPORTANT!

The manufacturer will not accept liability for any resulting damages caused by the non-observance of this manual or any unauthorized modification to the system.

- Always disconnect power from the mains, when system is not used. Only handle the power cord by the plug. Never pull out the plug by tugging the power cord.
- Always operate the unit with the AC ground wire connected to the electrical system ground.
- Avoid flames and do not put close to flammable liquids or gases.
- Avoid ground loops! Always be sure to connect the power amps and the mixing console to the same electrical circuit to ensure the same phase!

- Avoid installing your equipment very near radio or TV sets, mobile phones, etc., as these can cause RF (radio frequency) interference.
- Before changing your grounds around, always turn your amplifiers down.
- Before connecting or disconnecting the power cord, make sure that the ON/OFF switch is in the OFF position.
- Before switching on or off, make sure that the sound system's amplifiers are off or turned down: this will avoid signal peaks, which are annoying and sometimes dangerous (particularly for speaker enclosures).
- Do not connect this device to a dimmer pack.
- Do not drive the inputs with a signal level higher than required to drive the equipment to full output.
- Do not insert objects into air vents.
- Do not open this device. Risk: hazardous radiation exposure.
- Do not switch the system on and off in short intervals, as this would reduce the system's life.
- Extreme frequency boosts in connection with a high input signal level may lead to overdriving your equipment. Should this occur, it is necessary to reduce the input signal level by using the INPUT control.
- For replacement use fuses of same type and rating only.
- If device is dropped or struck, disconnect mains power supply immediately. Have a qualified engineer inspect for safety before operating.
- If the system has been exposed to drastic temperature fluctuation (e.g. after transportation), do not switch it on immediately. The arising condensation water might damage your system. Leave the system switched off until it has reached room temperature.
- Make sure that the available voltage is not higher than stated on the rear panel.
- Make sure that the power cord is never crimped or damaged. Check the device and the power cord from time to time.
- Make sure that the signals into the mixer are balanced, otherwise hum could be created.
- Make sure that there is sufficient room on all sides of the system for air circulation.
- Make sure you do not use the wrong kind of cables or defective cables.
- Make sure you use DI boxes to balance unbalanced signals; All incoming signals should be clear.
- Never let the power cord come into contact with other cables! Handle the power cord and all connections with the mains with particular caution!
- Never remove warning or informative labels from the unit.
- Never use anything to cover the ground contact.
- Only use device indoors, avoid contact with water or other liquids.
- Please turn off the power switch, when changing the power cord or signal cable, or select the input mode switch.
- Prevent distortion! Make sure that all components connected to the Odin have sufficient power ratings. Otherwise distortion will be generated because the components are operated at their limits.
- Repairs, servicing and electric connection must be carried out by a qualified technician.
- Sometimes, when you want to send one signal to more than one amplifier, you should use a signal distributor.
- The best way (even if not always feasible) to avoid ground loops is to connect the electric ground of all the equipment to a single central point ("star" system). In this case, the central point can be the mixer.
- To avoid or solve hum and buzzing troubles, try different combinations of lifting grounds on units that are supplied with ground lift switches or make sure all chassis are connected to earth ground, either through the A.C. power cord ground or by the front panel rack mount screws.
- To emphasize a frequency range, you do not necessarily have to move its respective slider upwards; instead, try lowering surrounding frequency ranges. This way, you avoid causing the next piece of equipment in your sound path to overdrive. You also preserve valuable dynamic reserve ("headroom").
- When connecting the other parts of your sound system, watch out for the so-called "ground loops".
- WARRANTY: Till one year after date of purchase.

Connection with the mains

Connect the device to the mains with the power-plug.

Always pay attention, that the right color cable is connected to the right place.

International	EU Cable	UK Cable	US Cable	Pin
L	BROWN	RED	YELLOW/COPPER	PHASE
N	BLUE	BLACK	SILVER	NEUTRAL
	YELLOW/GREEN	GREEN	GREEN	PROTECTIVE GROUND

Make sure that the device is always connected properly to the earth!

Improper installation can cause serious damage to people and property!



Return Procedure



Returned merchandise must be sent prepaid and in the original packing, call tags will not be issued. Package must be clearly labeled with a Return Authorization Number (RMA number). Products returned without an RMA number will be refused. Highlite will not accept the returned goods or any responsibility. Call Highlite 0031-455667723 or mail offersales@highlite.com and request an RMA prior to shipping the fixture. Be prepared to provide the model number, serial number and a brief description of the cause for the return. Be sure to properly pack fixture, any shipping damage resulting from inadequate packaging is the customer's responsibility. Highlite reserves the right to use its own discretion to repair or replace product(s). As a suggestion, proper UPS packing or double-boxing is always a safe method to use.

Note: If you are given an RMA number, please include the following information on a piece of paper inside the box:

- 01) Your name
- 02) Your address
- 03) Your phone number
- 04) A brief description of the symptoms

Claims

The client has the obligation to check the delivered goods immediately upon delivery for any shortcomings and/or visible defects, or perform this check after our announcement that the goods are at their disposal. Damage incurred in shipping is the responsibility of the shipper; therefore the damage must be reported to the carrier upon receipt of merchandise.

It is the customer's responsibility to notify and submit claims with the shipper in the event that a fixture is damaged due to shipping. Transportation damage has to be reported to us within one day after receipt of the delivery.

Any return shipment has to be made post-paid at all times. Return shipments must be accompanied with a letter defining the reason for return shipment. Non-prepaid return shipments will be refused, unless otherwise agreed in writing.

Complaints against us must be made known in writing or by fax within 10 working days after receipt of the invoice. After this period complaints will not be handled anymore.

Complaints will only then be considered if the client has so far complied with all parts of the agreement, regardless of the agreement of which the obligation is resulting.

Description of the device

Features

The Odin is our new solution for all entertainers who need a professional, robust and roadproof speaker system. Owing to the efficient class-D power amplifier and the built-in DSP protection system, it is almost impossible to deform your sound in normal conditions. High-end CELESTION components provide lots of sound pressure, as well as highly detailed sound.

- Power supply: 100-240V AC, 50Hz/60Hz
- Power consumption: 2000W
- System: Active Subwoofer, Active Array Element
- AMP power: 1500 W Continuous Class D, 6000W Peak
- Speaker: 18" (450mm) CELESTION, Ferrite Magnet Subwoofer, 4" Voice Coil, 1200W/RMS, Water Resistant Coating
- Frequency Response (+/-3dB): 30 Hz - 120 Hz
- MAX SPL @ 1 m: 136dB
- Cooling: passive cooling + forced cooling inside
- Audio connector: 3-pin XLR connector IN/OUT
- Data connector: RJ45 Data IN/LINK cascading connector
- External control: 9 fixed presets + 1 editable preset, power switch with LED indicators for CLIP/SIG/PROT
- DSP processor: 32bit , 24bit/48kHz audio conversion AD/DA
- Electronic Protections: Thermal/Convection-Fan/Overload/Digital Limiter/Compressor
- Mains connector: Neutrik PowerCON connector IN/OUT
- Enclosure construction: 18 mm birch plywood, resistant black paint, 1,5T metal grill with foam, rubber feet, two handles on each side, water resistant coating
- Mounting: M20 metal polemount, 4-point suspension
- Fuse: T6,3AL/250V
- Dimensions: 700 x 634 x 665 mm (LxWxH)
- Weight: 58,5 kg



Power cable and network cable are NOT included



Optional accessories:

[D3900](#) – ODIN T-8A Line Array Satellite

[D3910](#) – ODIN FB-01 Flybar

[D3911](#) – ODIN FB-02 Flybar

[D3912](#) – ODIN PM-01 Polemount Adapter

[D3915](#) – ODIN CL-4 Connect

Overview

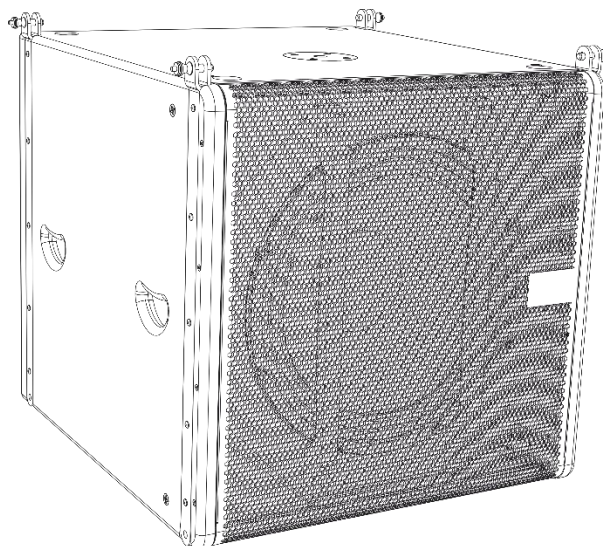

Fig. 01

Backside

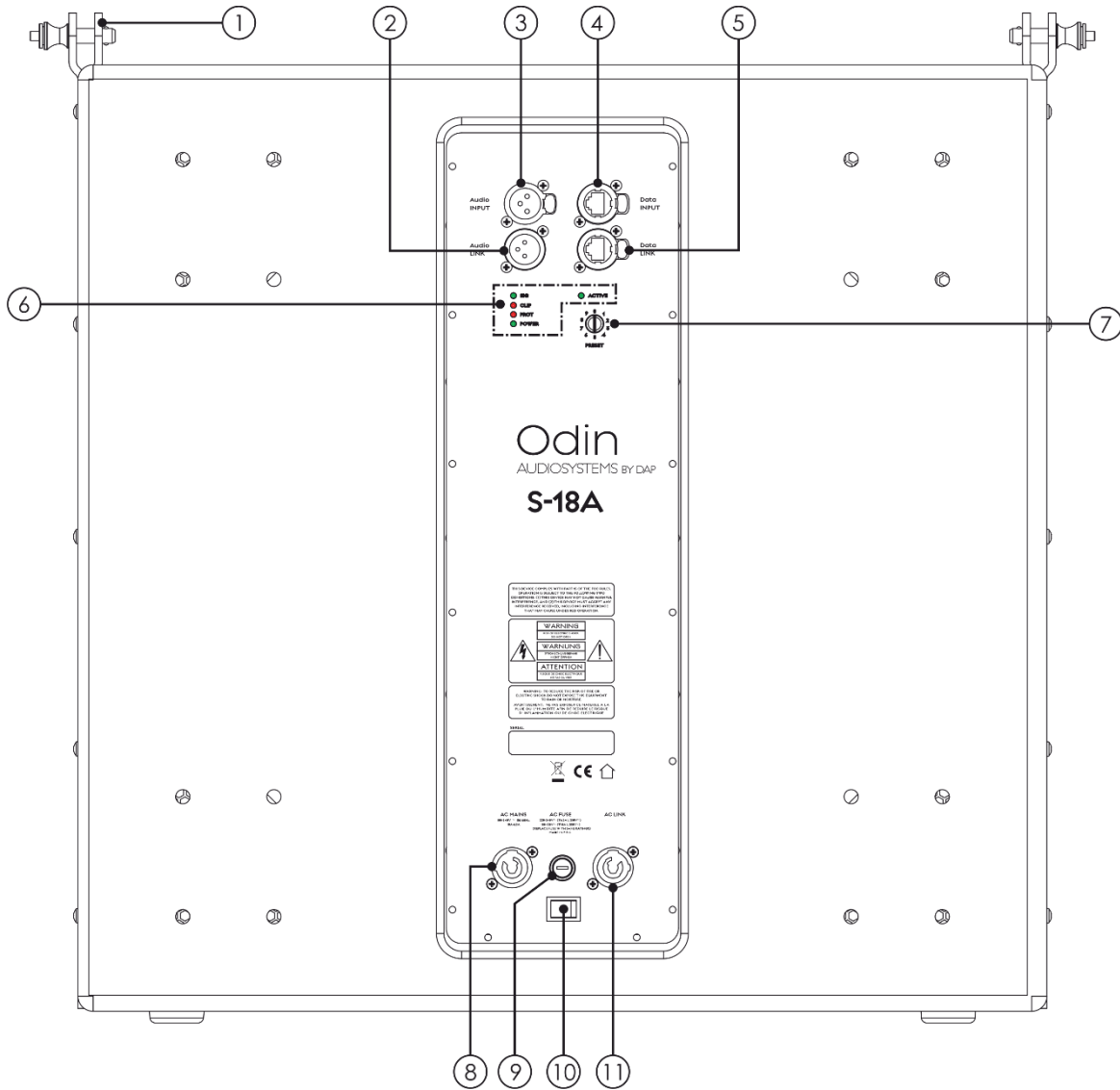

Fig. 02

- ① **Rigging pin**
- ② **3-pin XLR audio connector LINK**
Connected in parallel with the XLR input (03). Use the connector to send an audio signal to another active speaker.
- ③ **3-pin XLR audio connector IN**
Balanced XLR line level input connector.
- ④ **RJ45 data connector IN**
RJ45 data input connector.
- ⑤ **RJ45 data connector LINK**
RJ45 data output connector for cascading connections.
- ⑥ **LED indicators SIG/CLIP/PROT/POWER/ACTIVE**
The indicators light up to indicate the status of the input signal.
- ⑦ **10-position preset selector**
Turn the selector to choose one of the 10 equalizer presets. See page 8 for more information.
- ⑧ **PowerCON 100-240V AC power connector IN (Blue)**
Connect to an appropriate power supply.
- ⑨ **Fuse T6,3AL/250V**
- ⑩ **Power switch ON/OFF**
- ⑪ **PowerCON 100-240V AC power connector LINK (Gray)**
This output is connected in parallel with the PowerCON input (08) and can be used for powering another active speaker.

Installation

Remove all packing materials from the Odin S-18A Line Array Sub. Check if all foam and plastic padding is removed. Connect all cables.

Do not supply power before the whole system is set up and connected properly.

Always disconnect from electric mains power supply before cleaning or servicing.

Damages caused by non-observance are not subject to warranty.

Connection Example

Make your initial connections with all the equipment powered off and ensure that all the main volume controls are turned completely to the minimum. Follow the steps below. See fig. 04 for more information.

- 01) Connect one end of the XLR cable to your audio mixer (to MAIN OUT MONO) and the other end of the cable to the audio signal input **(03)** on your first speaker.
- 02) Using an XLR cable, connect the audio signal link **(02)** on your first speaker to the audio signal input **(03)** on your second speaker. Repeat this step to connect multiple speakers.
- 03) Using a PowerCON power cord, connect the first speaker's power input **(08)** to the power supply.
- 04) Using PowerCON power cords, connect the first active speaker's power link **(11)** to the second speaker's power input **(08)**. Repeat this step to connect the third and fourth speaker. **Please note that it is allowed to connect only up to 4 speakers per phase (16A).**
- 05) In order to enable data signal reception, connect the CL-4 Connect **(D3915)** to the first speaker's RJ45 data input **(04)**, using a UTP/CAT-5 cable. Connect the first speaker's data link **(05)** to the second speaker's data input **(04)**. Repeat this step to connect multiple speakers. **Please note, that to ensure proper data reception, it is allowed to connect up to 12 speakers.**
- 06) Use the PFL function to get the proper input level for the mixer and adjust the Main Mix Level.
- 07) After using your equipment, turn off your active speaker cabinets first, then the mixer.

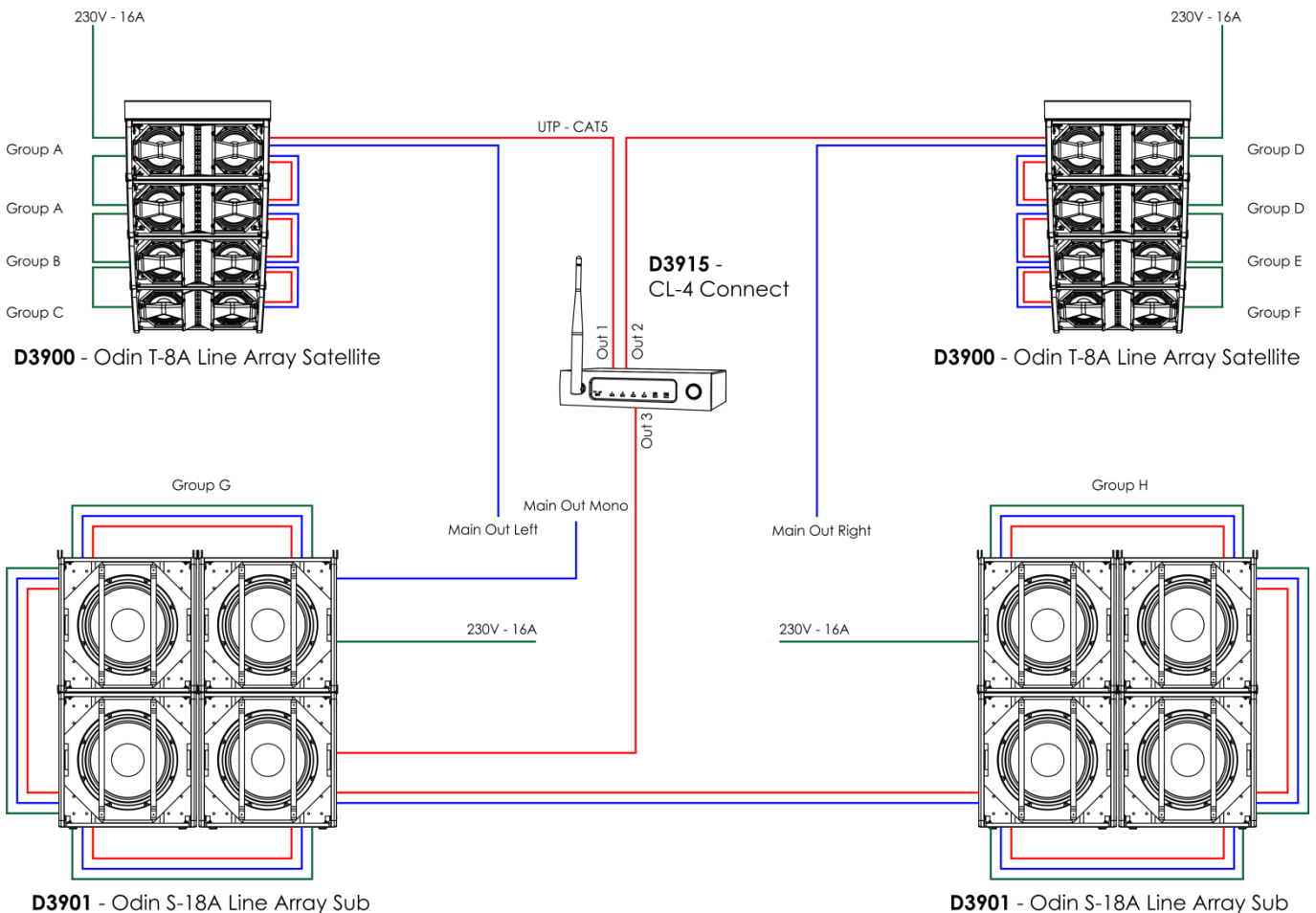

Fig. 03

Set Up and Operation

Follow the directions below, as they pertain to your preferred operation mode.

Before plugging the unit in, always make sure that the power supply matches the product specification voltage. Do not attempt to operate a 115V specification product on 230V power, or vice versa.

Preset Selector

01) Turn the preset selector **(07)** to choose one of the 10 presets. See below for more information.

Presets

The below presets can be selected according to the preferences of the end user. Each preset consists of a set of properties, unique for every purpose and location. The presets differ by the EQ, Gain and Delay settings.

PRESET	NAME	DESCRIPTION
0	Default	Preset for multipurpose use, set at a level of 0 dB
1	Default Phase 180° Inverted	Preset (Phase 180° Inverted) for multipurpose use, set at a level of 0 dB.
2	Low Sub	Preset for live use (Bands/Performances), crosspoint at 105 Hz, set at a level of 0 dB.
3	Low Sub Phase 180° Inverted	Preset for live use (Bands/Performances) Phase 180° Inverted, crosspoint at 105 Hz, set at a level of 0 dB.
4	Entertainment	Preset for entertainment use (DJ/Playback), crosspoint at 125 Hz, set at a level of 0 dB.
5	Entertainment Phase 180° Inverted	Preset for entertainment use (DJ/Playback) Phase 180° Inverted, crosspoint at 125 Hz, set at a level of 0 dB.
6	Cardioid	Use the in-phase preset (0) on the front side and the out-of-phase (polarity reverse) preset (6) on the rear.
7	End Fire	Delaying front subwoofer @1,6m between front-front (@freq 53 Hz)
8	EMPTY	
9	ODIN Editor	Default settings, configurable with the ODIN Editor.

Connection Cables

Take care of your cables, always holding them by the connectors and avoiding knots and twists when coiling them: This gives the advantage of increasing their life and reliability.

Periodically check your cables. A great number of problems (faulty contacts, ground hum, discharges, etc.) are caused entirely by using unsuitable or faulty cables.

For these applications the unit provides XLR and CAT-5 connectors to easily interface with most professional audio devices. Follow the configuration examples below for your particular connection.

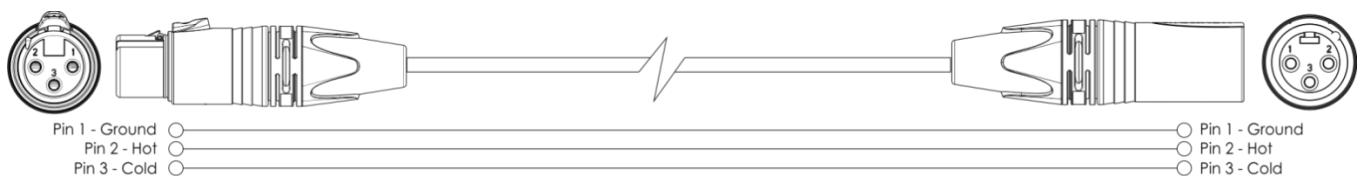

How to Make a Data Cable

A standard ETHERNET cable can be used to replace the data cable required to transmit data.

Please follow the instructions below in order to create an extra net cable.

Take a standard net cable (CAT-5/ 5E /6) and connect it to the RJ45 connector, as shown in the picture below (fig. 04). The wires should now be colored as follows:

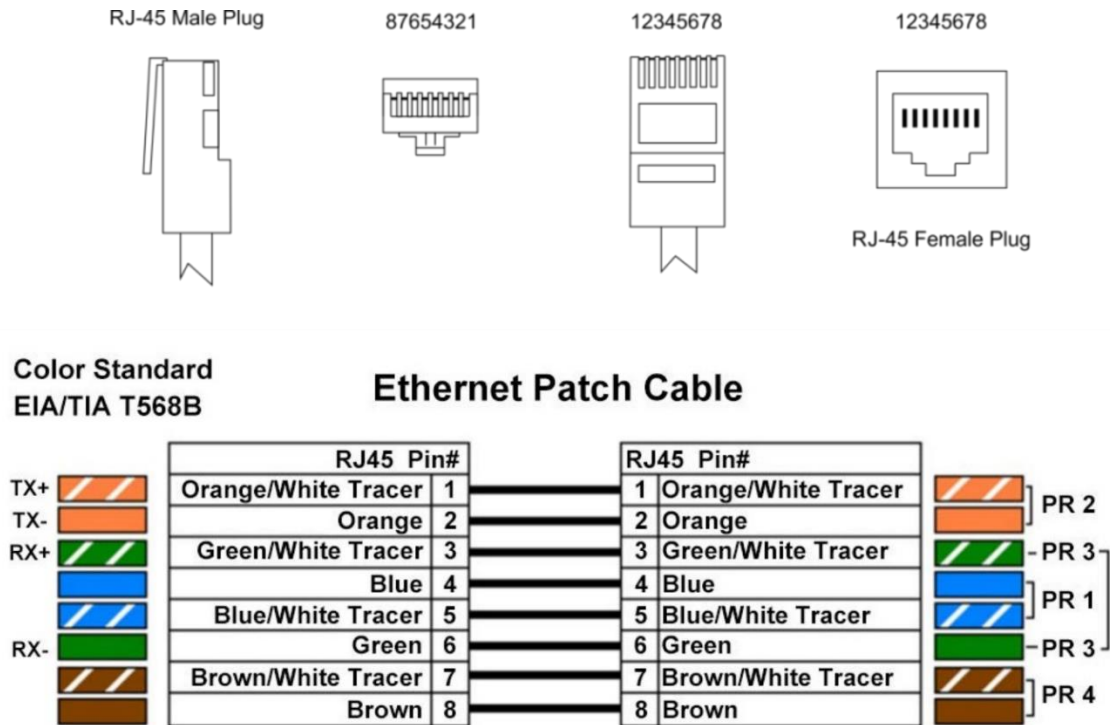

Fig. 04

Maintenance

The Odin S-18A Line Array Sub requires almost no maintenance. However, you should keep the unit clean. Disconnect the mains power supply, and then wipe the cover with a damp cloth. Do not immerse in liquid. Do not use alcohol or solvents.

Keep connections clean. Disconnect electric power, and then wipe the connections with a damp cloth. Make sure connections are thoroughly dry before linking equipment or supplying electric power.

Troubleshooting

This troubleshooting guide is meant to help solve simple problems. If a problem occurs, carry out the steps below in sequence until a solution is found. Once the unit operates properly, do not carry out following steps.

- 01) If the device does not operate properly, unplug the device.
- 02) Check the fuse, power from the wall, all cables, etc.
- 03) If all of the above appears to be O.K., plug the unit in again.
- 04) If you are unable to determine the cause of the problem, do not open the device, as this may damage the unit and the warranty will become void.
- 05) Return the device to your Dap Audio dealer.

Product Specifications

Odin S-18A Line Array Sub

System:	Active Subwoofer, Active Array Element
AMP power:	1500 W Continuous Class D, 6000W Peak
Speaker:	18" (450mm) CELESTION, Ferrite Magnet Subwoofer, 4" Voice Coil, 1200W/RMS, Water Resistant Coating
Frequency response (+/-3dB):	30 Hz - 120 Hz
MAX SPL @ 1 m:	136dB
Cooling:	Passive cooling + forced cooling inside
Audio connector:	3-pin XLR connector IN/OUT
Data connector:	RJ45 data IN/LINK cascading connector
External controls:	9 fixed presets + 1 editable preset, power switch with LED indicators for CLIP/SIG/PROT
DSP processor:	32bit , 24bit/48kHz audio conversion AD/DA
Electronic protections:	Thermal/Convection-Fan/Overload/Digital Limiter/Compressor
Mains connector:	Neutrik PowerCON connector IN/OUT
Power supply:	100-240V AC, 50Hz/60Hz
Power consumption:	2000W
Enclosure construction:	18 mm birch plywood, resistant black paint, 1,5T metal grill with foam, rubber feet, two handles on each side, water resistant coating
Mounting:	M20 metal polemount, 4-point suspension
Fuse:	T6,3AL/250V
Dimensions:	700 x 634 x 665 mm (LxWxH)
Net Weight:	58,5 kg

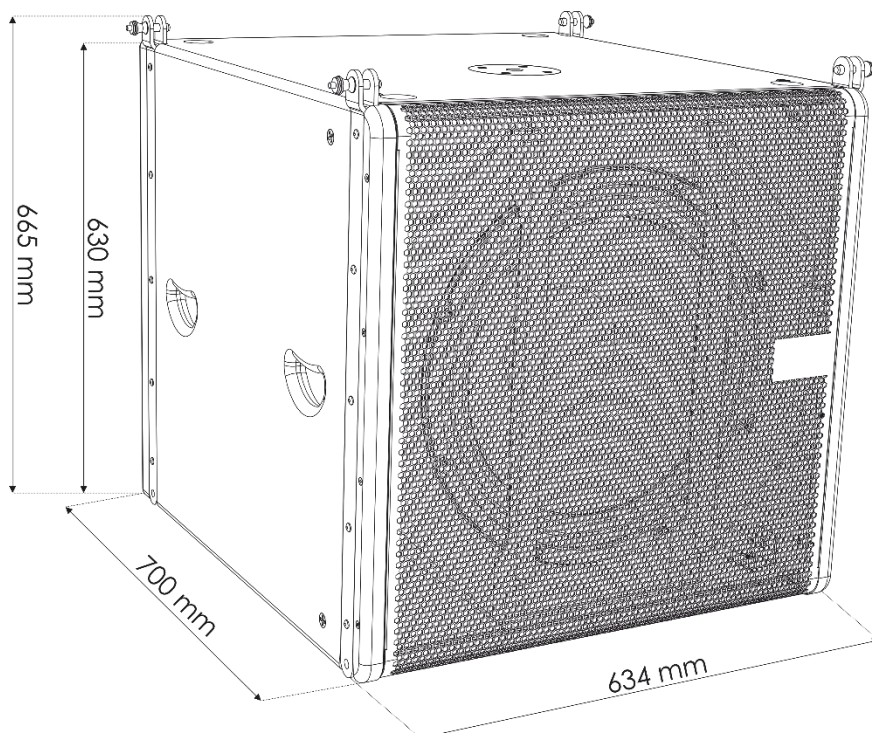

Design and product specifications are subject to change without prior notice.



Website: www.odin-audiosystems.com

Email: service@highlife.com

Odin

AUDIOSYSTEMS BY DAP

©2019 ODIN