



PST-115

ORDERCODE D6320



Highlite International B.V.

Vestastraat 2
6468 EX Kerkrade
The Netherlands

SHOWELECTRONICS FOR PROFESSIONALS

Congratulations!

You have bought a great, innovative product from DAP Audio.

The DAP Audio brings excitement to any venue. Whether you want simple plug-&-play action or a sophisticated show, this product provides the effect you need.

You can rely on DAP Audio, for more excellent audio products.

We design and manufacture professional audio equipment for the entertainment industry.

New products are being launched regularly. We work hard to keep you, our customer, satisfied.

For more information: iwant@dap-audio.info

You can get some of the best quality, best priced products on the market from DAP Audio.

So next time, turn to DAP Audio for more great audio equipment.

Always get the best -- with DAP Audio !

Thank you!



DAP Audio

DAP Audio PST-115™ Product Guide

Warning	2
Unpacking Instructions	2
Safety-instructions	2
Operating Determinations	3
Return Procedure	3
Claims	3
Description	4
Features	4
Overview	4
Operation	5
Setup of the PST-115	5
Installation	5
Maintenance	5
Product Specifications	6

WARNING

**FOR YOUR OWN SAFETY, PLEASE READ THIS USER MANUAL CAREFULLY
BEFORE YOUR INITIAL START-UP!**

Unpacking Instructions

Immediately upon receiving this product, carefully unpack the carton and check the contents to ensure that all parts are present, and have been received in good condition. Notify the dealer immediately and retain packing material for inspection if any parts appear damaged from shipping or the carton itself shows signs of mishandling. Save the carton and all packing materials. In the event that a fixture must be returned to the factory, it is important that the fixture be returned in the original factory box and packing.

Your shipment includes:

- DAP PST-115
- User manual

 **CAUTION!** 
Keep this system away from rain and moisture!

SAFETY INSTRUCTIONS

Every person involved with the installation, operation and maintenance of this system has to:

- be qualified
- follow the instructions of this manual

 **CAUTION! Be careful with your operations.** 
**With a dangerous voltage you can suffer
a dangerous electric shock when touching the wires!**

Before you initial start-up, please make sure that there is no damage caused by transportation. Should there be any, consult your dealer and do not use the system.

To maintain perfect condition and to ensure a safe operation, it is absolutely necessary for the user to follow the safety instructions and warning notes written in this manual.

Please consider that damages caused by manual modifications to the system are not subject to warranty.

This system contains no user-serviceable parts. Refer servicing to qualified technicians only.

IMPORTANT:

The manufacturer will not accept liability for any resulting damages caused by the non-observance of this manual or any unauthorized modification to the system.

- Never leave any cables lying around.
- Never use the device during thunderstorms, unplug the device immediately.
- Do not open the device and do not modify the device.
- Do not shake the device. Avoid brute force when installing or operating the device.
- Only operate the device after having familiarized with its functions.
- If the connection cable is damaged, it has to be replaced by a qualified technician.
- Avoid flames and do not put close to flammable liquids or gases.

- Make sure you don't use the wrong kind of cables or defective cables.
- Make sure that the device is not exposed to extreme heat, moisture or dust.
- Make sure that the connection cable is never crimped or damaged.
- If your Dap device fails to work properly, discontinue use immediately. Pack the unit securely (preferably in the original packing material), and return it to your Dap dealer for service.
- If the speaker is dropped or struck, disconnect immediately. Have a qualified engineer inspect for safety before operating.
- Repairs, servicing and electric connection must be carried out by a qualified technician.
- WARRANTY: Till one year after date of purchase.

OPERATING DETERMINATIONS

This system is not designed for permanent operation. Consistent operation breaks will ensure that the system will serve you for a long time without defects.

If this system is operated in any other way, than the one described in this manual, the product may suffer damages and the warranty becomes void.

Any other operation may lead to dangers like short-circuit, burns, electric shock, etc.

You endanger your own safety and the safety of others!

Improper installation can cause serious damage to people and property !

Return Procedure

Returned merchandise must be sent prepaid and in the original packing, call tags will not be issued. Package must be clearly labeled with a Return Authorization Number (RMA number). Products returned without an RMA number will be refused. Highlite will not accept the returned goods or any responsibility. Call Highlite 0031-455667723 or mail offersales@highlite.nl and request an RMA prior to shipping the fixture. Be prepared to provide the model number, serial number and a brief description of the cause for the return. Be sure to properly pack fixture, any shipping damage resulting from inadequate packaging is the customer's responsibility. Highlite reserves the right to use its own discretion to repair or replace product(s). As a suggestion, proper UPS packing or double-boxing is always a safe method to use.

Note: If you are given an RMA number, please include the following information on a piece of paper inside the box:

- 1) Your name
- 2) Your address
- 3) Your phone number
- 4) A brief description of the symptoms

Claims

The client has the obligation to check the delivered goods immediately upon delivery for any short-comings and/or visible defects, or perform this check after our announcement that the goods are at their disposal. Damage incurred in shipping is the responsibility of the shipper; therefore the damage must be reported to the carrier upon receipt of merchandise.

It is the customer's responsibility to notify and submit claims with the shipper in the event that a fixture is damaged due to shipping. Transportation damage has to be reported to us within one day after receipt of the delivery.

Any return shipment has to be made post-paid at all times. Return shipments must be accompanied with a letter defining the reason for return shipment. Non-prepaid return shipments will be refused, unless otherwise agreed in writing.

Complaints against us must be made known in writing or by fax within 10 working days after receipt of the invoice. After this period complaints will not be handled anymore.

Complaints will only then be considered if the client has so far complied with all parts of the agreement, regardless of the agreement of which the obligation is resulting.

Description of the device

Features

The PST-115 is a uni direction 15W speaker incl. 100V line transformer. The PST-115 is equipped with a 60 cm long fixed cable with six cores allowing you to choose the appropriate impedance. The PST-115 is recommended for music or speech reproduction, is weather-proof and suitable for indoor and outdoor use.

Overview



Fig. 1

Operation

Connecting the PST-115

The PST-115 is equipped with a fixed 6-core cable which allows you to set the impedance and Power in a way which suits your application best.

The **Black wire** is the **common** connection. The table below shows all possible connections.

		100V	70V	50V
Brown	166Ω	-	-	15W
Red	326Ω	-	15W	7,5W
Orange	666Ω	15W	7,5W	3,75W
Gray	1,33kΩ	7,5W	3,75W	-
White	2,66kΩ	3,75W	-	-

Installation

Remove all packing materials from the PST-115. Check that all foam and plastic padding is removed. Make sure that you understand 100V systems.

In 50V/70V/100V system amplifiers, you can only use one high impedance output at a time. This means that you can only use the 50V output or the 70V output or the 100V output. Never use two outputs at the same time!

Make sure that all speakers connected to a 50V/70V/100V system amplifier are wired in parallel.

The total power of all speakers summed together should never exceed the total power of the amplifier in a 50V, 70V or a 100V system!

If you have any doubts, ask a trained professional to install your 100V system.

Damages caused by non-observance are not subject to warranty.

Maintenance

The PST-115 requires almost no maintenance. However, you should keep the unit clean. Disconnect the mains power supply, and then wipe the cover with a damp cloth. Do not immerse in liquid. Keep connections clean. Disconnect electric power, and then wipe the audio connections with a damp cloth. Make sure connections are thoroughly dry before linking equipment or supplying electric power.

Product Specifications

Input power:	RMS 15W
Output power:	3,75W, 7.5W, 15W
Speaker:	Single 5,5" paper/plastic cone speaker
Input voltage:	50, 70, 100V
Impedance 100V:	2,66 kilo-Ohm, 1,33 kilo-Ohm, 666 Ohm
70V:	1,33 kilo-Ohm/666 Ohm/326 Ohm
50V:	666 Ohm/326 Ohm/166 Ohm
Frequency response:	150 Hz -20 kHz
S.P.L.:	94 dB (1W/M)
Material:	ABS resin
IP rating:	IP44

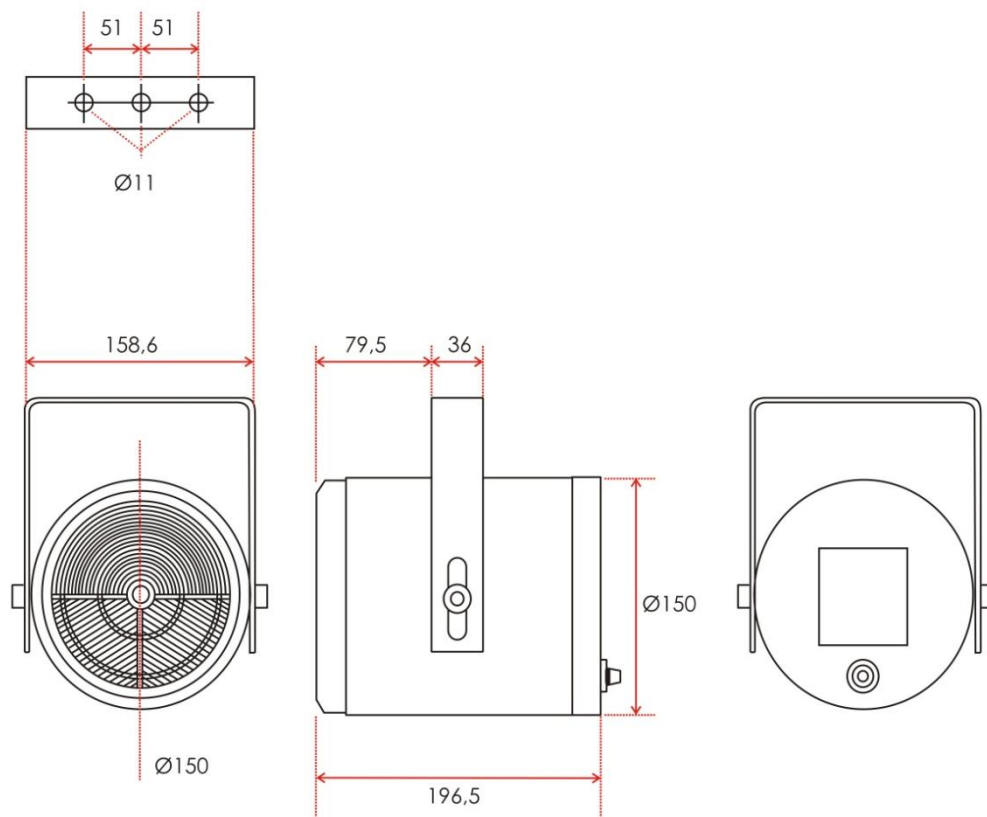

Design and product specifications are subject to change without prior notice.



Website: www.Dap-audio.info
Email: service@highlite.nl



© 2011 Dap Audio.