

**Colour
is our nature**

50W DMX/RDM Full-Colour (RGB) Dimmable LED Driver

POWERdrive

POWERdrive's dynamic response can be tuned to fit any content - from exceptionally smooth fades in architecture to fast-paced video in entertainment. This constant current LED driver is DMX/RDM compatible, and allows you to create your colour or dynamic show without an external controller. Symbiosis ensures the LED driver works seamlessly together with LED modules, controls and intelligent luminaire elements.

Product offering



POWERdrive 562/A

Part number P/N	PW0562A1
Product description	POWERdrive, 50W, DMX/RDM, 3 control channels, constant current, 3x 55V outputs, square metal/plastic

Programming tools

Programming interface	TOOLbox pro (TLU20504)
Programming cable set	TOOLbox pro to LED driver, programming cable, 5pcs (TLC03051)
Programming software	FluxTool

Warranty

Warranty period	General Terms and Conditions
-----------------	--

Order number configurator

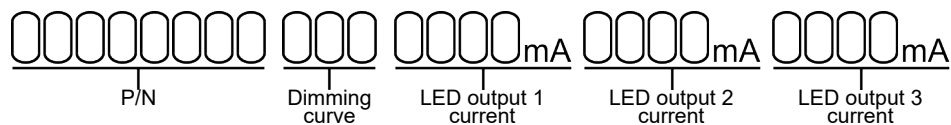

P/N	LED driver part number
LED output current	Enter value in 10mA increments, e.g. "0260", "1010", etc.
Dimming curve	"LOG" for logarithmic (default) "LIN" for linear "SQU" for square

Input characteristics

Nominal input voltage range AC	120 - 250V (ENEC), 120 - 277V (UL)
Nominal input voltage range DC	120 - 250V
Maximum input current AC	0.7A @ 120V
Input frequency range	50 - 60Hz
Efficiency at full load	89%
Power factor at full load	>0.9
THD at full load	<20%
Maximum inrush current AC	30mA ² s @ 120V
Surge protection	1kV differential mode (DM) 2kV common mode (CM)
Maximum standby power	<0.5W

Output characteristics

Maximum LED output power	50W
Number of LED outputs	3 (UL Class 2)
Programmable LED output current range	200 - 1050mA
LED output type	programmable in 10mA steps via DMX terminal and FluxTool
LED output current tolerance	+/- 5% at programmed LED output current
LED output voltage range	2 - 55V

Control characteristics

Control channels	3
Control protocol	DMX/RDM
Dimming range	100% - 0.1%
Dimming curve options	Logarithmic (default) Linear Square
Dimming method	Hybrid HydraDrive

Dimming curves

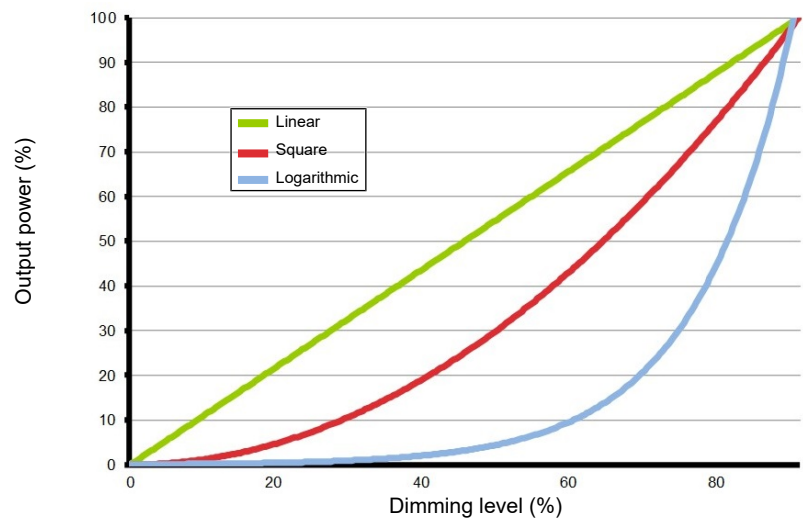

Environmental conditions

Operating ambient temperature (Ta) range	-20 °C to +50 °C
Maximum operating case temperature (Tc max)	85 °C

LED driver protection

Thermal	The LED output current is decreased whenever the internal LED driver temperature exceeds factory preset temperature. The LED output current is increased again once the internal LED driver temperature drops below this internal temperature threshold. If the internal LED driver temperature continues to increase, despite a decrease in output current, the LED driver will shut down.
LED output short circuit	The LED output current is cut off whenever the LED driver detects a short-circuit. The LED driver will attempt a restart every 400ms after a short-circuit is detected.
LED output overload	The LED driver decreases the LED output current sequentially, until it reaches its maximum rated power, whenever a load that exceeds the LED driver's maximum rated power is connected to the LED output.
Reverse polarity	The LED driver will not yield any current if the polarity of the load on the LED output is reversed. This situation will not damage the LED driver but may damage the LED load.

LED protection

Thermal protection LED	An external NTC thermistor, which is placed on a PCB near the LEDs, can be connected to the driver via the LEDcode/NTC terminals. The output current to the LEDs is then decreased by 75% whenever the NTC exceeds a maximum allowable temperature, which is specified by the user in the FluxTool software. The default NTC temperature limit is set to 70 °C.
Thermistor value	47kΩ
Suitable thermistors	Leaded: Vishay, P/N 238164063473 Screw: Vishay, P/N NTCASCWE3473J

LED driver mechanical details

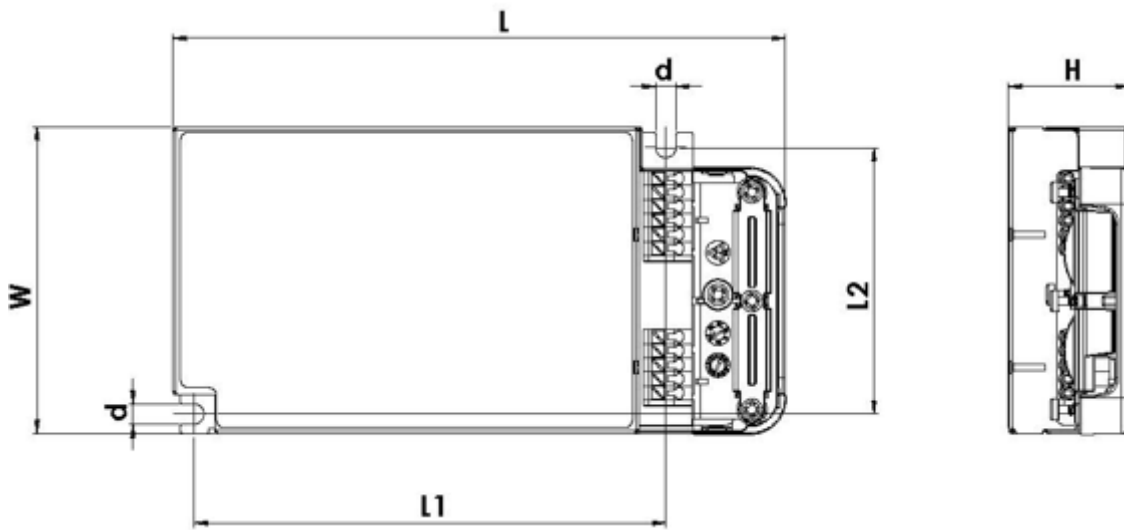

Length (L)	typical: 152.5 mm / 6 in
Width (W)	typical: 76 mm / 2.99 in
Height (H)	typical: 30.1 mm / 1.19 in
Weight	372 g

Packaging

Products per box	6 or 45 pcs
------------------	-------------

Connector layout

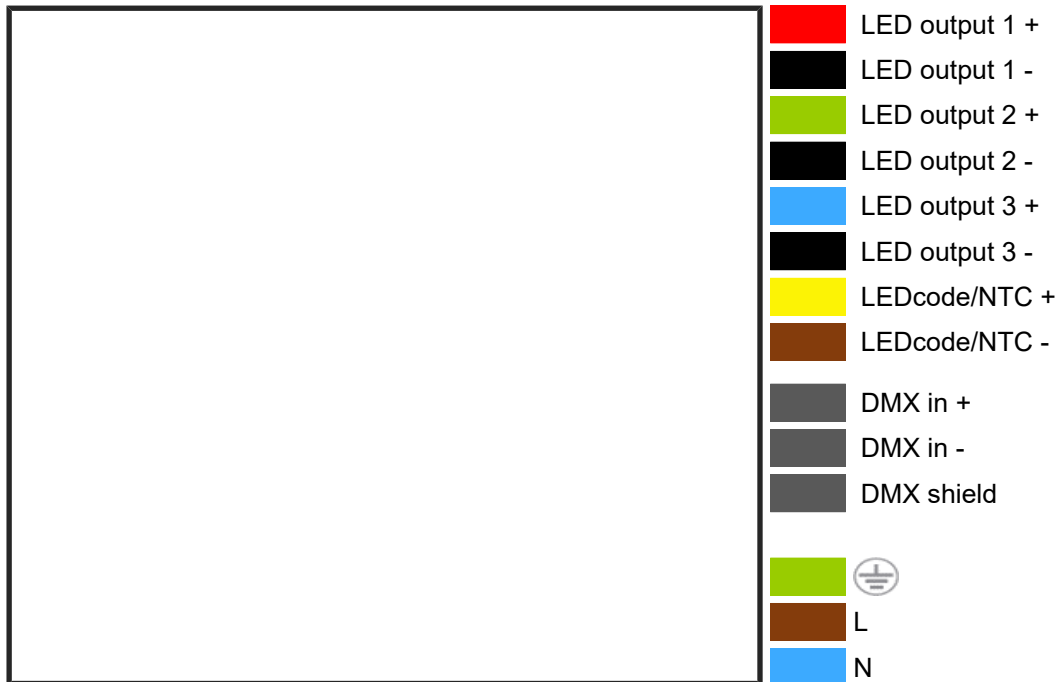

Wiring Specifications

Wire Type	AWG 20-16, 0.5-1.5mm ² solid or stranded copper
Wire strip length	9mm / 0.35in

Automatic circuit breakers (MCB)

Maximum loading	MCB type	B10	B13	B16	C10	C13	C16
	Number of LED drivers	14	18	22	14	18	22

Calibrated start-up procedure

For optimized DMX dimming performance

While switching the mains input voltage, the DMX signal to the LED driver needs to be at 100% (255). Unused or open LED outputs of the driver need to be disabled. This can be achieved by programming the driver with the eldoLED Fluxtool software. In the “Setup – Control menu”, select “Group scaling” for each unused or open LED output and change the actual value to ‘0’, and write into the driver. For all LED outputs in use, change the value to ‘255’.

Standards and compliance

UL, recognized component	UL 1310 UL 8750 (Class 2 output)
ENEC safety	EN 61347-1 EN 61347-2-13 (Emergency lighting)
ENEC performance	EN 62384
Conducted emissions	EN 55015
Radiated emissions	EN 55015
Radio disturbance characteristics	EN 55022
Harmonic current emissions	EN 61000-3-2
Electromagnetic immunity	EN 61547
DMX	E1.11 – 2008, USITT DMX512-A ANSI E1.20
RCM	AS/NZS 61347.1, AS/NZS 61347.2.13
Restriction of hazardous substances	RoHS3 (Directives 2011/65/EU-2015/863/EU)

Certifications



RCM independent control gear classification

Clearance type	Description	Distance
Height clearance to building element (HCB)	Minimum distance between the top of the control gear and any building element above it	50 mm
Minimum insulation clearance (MIC)	Minimum distance between the top of the control gear and the building insulation above it	50 mm
Side clearance to building element (SCB)	Minimum distance between the side of the control gear and any building element	50 mm
Side clearance to insulation (SCI)	Minimum distance between the side of the control gear and any building insulation	50 mm

Safety



FELV control terminals marked “Risk of electric shock” are not safe to touch. Dimming connected to FELV control terminal shall be insulated for Low Voltage supply of the control gear. Any terminals connected to the FELV circuit shall be protected against accidental contact.



Risk of electrical shock. May result in serious injury or death. Disconnect power before servicing or installing.



The LED driver may only be connected and installed by a qualified electrician. All applicable regulations, legislation, and building codes must be observed. Incorrect installation of the LED driver can cause irreparable damage to the LED driver and the connected LEDs.

Pay attention when connecting the LEDs: polarity reversal results in no light output and often damages the LEDs.



LED drivers are designed and intended to operate LED loads only. Powering non-LED loads may push the LED driver outside its specified design limits and is, therefore, not covered by any warranty.



eldoLED products are designed to meet the performance specifications as outlined at certain operating conditions in the data sheet. It is the responsibility of the fixture manufacturer to test and validate the design and operation of the system under expected and potential use cases, including faults.



Please observe voltage drop over long cable lengths. Longer cable lengths increase EMI susceptibility.



Product renderings and dimensional drawings are generic for the housing type. Product label, connector type and quantity may vary.

Europe, Rest of World

eldoLED B.V.
Science Park Eindhoven 5125
5692 ED Son
The Netherlands

E: info@eldoled.com
W: www.eldoled.com

North America

eldoLED America
One Lithonia Way
Conyers, GA 30012
USA

E: info@eldoled.com
W: www.eldoled.com
