



ENGLISH

LED PIXEL 1

V1

Ordercode: A9915120

Table of contents

Warning	2
Safety Instructions	2
Operating Determinations	3
Connection with the mains.....	4
Return Procedure.....	4
Claims.....	4
Description of the device	5
Features	5
Front.....	5
Installation	6
Setup and Operation	6
Control Modes.....	6
Setup LED Pixel 1 with Lighting Controller.....	6
Device Linking	7
Control Panel.....	7
DMX Addressing	7
Menu Overview.....	8
Main Menu Options	8
1. DMX Address	9
2. Segment Grouping.....	10
3. Pixel Range (Pxxx).....	11
4. Show / Self-Test MODE (Shxx)	13
DMX Channels	14
150 channels (RGB)	15
75 channels (RGB)	16
39 channels (RGB)	17
21 channels (RGB)	18
3 channels (RGB)	19
Maintenance	20
Troubleshooting	20
No Light	20
No Response to DMX.....	21
Product Specifications	22

Warning



**For your own safety, please read this user manual carefully
before your initial start-up!**



Unpacking Instructions

Immediately upon receiving this product, carefully unpack the carton and check the contents to ensure that all parts are present, and have been received in good condition. Notify the dealer immediately and retain packing material for inspection if any parts appear damaged from shipping or the carton itself shows signs of mishandling. Save the carton and all packing materials. In the event that a device must be returned to the factory, it is important that the device be returned in the original factory box and packing.

Your shipment includes:

- Artecta LED PIXEL 1
- User manual

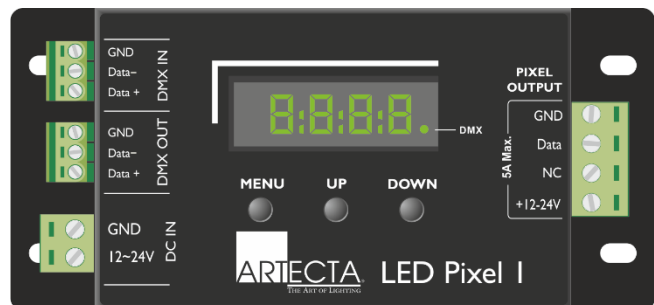

CAUTION!

**Keep this device away from rain and moisture!
Unplug mains lead before opening the housing!**



Safety Instructions

Every person involved with the installation, operation and maintenance of this device has to:

- be qualified
- follow the instructions of this manual



**CAUTION! Be careful with your operations.
With a dangerous voltage you can suffer
a dangerous electric shock when touching the wires!**



Before the initial start-up, please make sure that there is no damage caused by transportation. Should there be any, consult your dealer and do not use the device.

To maintain perfect condition and to ensure a safe operation, it is absolutely necessary for the user to follow the safety instructions and warning notes contained in this manual.

Please consider that damages caused by manual modifications to the device are not subject to warranty.

This device contains no user-serviceable parts. Refer servicing to qualified technicians only.

IMPORTANT:

The manufacturer will not accept liability for any resulting damages caused by the non-observance of this manual or any unauthorized modification to the device.

- Never let the power cord come into contact with other cables! Handle the power cord and all connections with the mains with particular caution!
- Never remove warning or informative labels from the device.
- Never use anything to cover the ground contact.
- Never leave any cables lying around.
- Do not open the device and do not modify the device.
- Do not connect this device to a dimmer pack.
- Do not switch the device on and off in short intervals, as this will reduce the device's life.
- Do not shake the device. Avoid brute force when installing or operating the device.
- Only use the device indoors, avoid contact with water or other liquids.
- Only operate the device after having checked if the housing is firmly closed and all screws are tightly fastened.
- Only operate the device after having familiarized with its functions.
- Avoid flames and do not put close to flammable liquids or gases.
- Always keep the case closed while operating.
- Always allow a free air space of at least 50 cm around the device for ventilation.
- Always disconnect power from the mains, when device is not used or before cleaning! Only handle the power cord holding it by the plug. Never pull out the plug by tugging the power cord.
- Make sure that the device is not exposed to extreme heat, moisture or dust.
- Make sure that the available voltage is not higher than stated on the rear panel.
- Make sure that the power cord is never crimped or damaged. Check the device and the power cord from time to time.
- If device was dropped or struck, disconnect mains power supply immediately. Have a qualified engineer inspect for safety before operating.
- If the device has been exposed to drastic temperature fluctuation (e.g. after transportation), do not switch it on immediately. The arising condensation water might damage your device. Leave the device switched off until it has reached room temperature.
- If your Artecta device fails to work properly, discontinue the use immediately. Pack the device securely (preferably in the original packing material), and return it to your Artecta dealer for service.
- For adult use only. The device must be installed beyond the reach of children. Never leave the device running unattended.
- Never attempt to bypass the thermostatic switch or fuses.
- The user is responsible for correct positioning and operating of the LED Dim 12. The manufacturer will not accept liability for damages caused by the misuse or incorrect installation of this device.
- Repairs, servicing and electric connection must be carried out by a qualified technician.
- WARRANTY: Till one year after date of purchase.

Operating Determinations

- This device is not designed for permanent operation. Consistent operation breaks will ensure that the device will serve you for a long time without defects.
- The maximum ambient temperature $t_a = 40\text{ °C}$ must never be exceeded.
- The relative humidity must not exceed 50 % with an ambient temperature of 40 °C .
- If this device is operated in any other way than the one described in this manual, the product may suffer damages and the warranty becomes void.
- Any other operation may lead to dangers like short-circuit, burns, electric shock, crash, etc.

You endanger your own safety and the safety of others!

Connection with the mains

Connect the device to the mains with the power-plug.

Always check if the right color cable is connected to the right place.

International	EU Cable	UK Cable	US Cable	Pin
L	BROWN	RED	YELLOW/COPPER	PHASE
N	BLUE	BLACK	SILVER	NEUTRAL
	YELLOW/GREEN	GREEN	GREEN	PROTECTIVE GROUND

Make sure that the device is always properly connected to the earth!

Improper installation can cause serious injuries and/or damage of property!



Return Procedure



Returned merchandise must be sent prepaid and in the original packing, call tags will not be issued. Package must be clearly labeled with a Return Authorization Number (RMA number). Products returned without an RMA number will be refused. Highlite will not accept the returned goods or any responsibility. Call Highlite 0031-455667723 or mail aftersales@highlite.com and request an RMA prior to shipping the device. Be prepared to provide the model number, serial number and a brief description of the cause for the return. Be sure to properly pack device, any shipping damage resulting from inadequate packaging is the customer's responsibility. Highlite reserves the right to use its own discretion to repair or replace product(s). As a suggestion, proper UPS packing or double-boxing is always a safe method to use.

Note: If you are given an RMA number, please include the following information on a piece of paper inside the box:

- 01) Your name
- 02) Your address
- 03) Your phone number
- 04) A brief description of the symptoms

Claims

The client has the obligation to check the delivered goods immediately upon delivery for any shortcomings and/or visible defects, or perform this check after our announcement that the goods are at their disposal. Damage incurred in shipping is the responsibility of the shipper; therefore the damage must be reported to the carrier upon receipt of merchandise.

It is the customer's responsibility to report and submit claims with the shipper in the event that a device is damaged due to shipping. Transportation damage has to be reported to us within one day after receipt of the delivery.

Any return shipment has to be made post-paid at all times. Return shipments must be accompanied with a letter defining the reason for return shipment. Non-prepaid return shipments will be refused, unless agreed otherwise in writing.

Complaints against us must be prepared in writing or sent by fax within 10 working days after receipt of the invoice. After this period complaints will not be handled anymore.

Complaints will only then be considered if the client has so far complied with all parts of the agreement, regardless of the agreement from which the obligation is resulting.

Description of the device

The Artecta LED Pixel 1 is a DMX to SPI converter with multiple functions.

SPI is being used to pixel-control digital LED strips. With the LED Pixel 1 you have the possibility to choose one of 6 SPI protocols to control the LED strips.

The LED Pixel 1 is suitable to use with constant-voltage LED strips. With the Phoenix terminal connections it is easy to connect the device to the mains power supply and to connect LED strips.

Features

- Power supply: 12–24 V DC
- Wide range of SPI controls built-in
- Input Protocol: DMX-512
- DMX In/Out: 3-pin terminal connector
- Output Protocol: SPI
- SPI control: UCS2903, UCS2904, WS2801, WS2812, WS2911, TM1812, APA101, P943F
- Pixel Control:
 - 1CH W
 - 2CH Dynamic White
 - 3CH RGB
 - 4CH RGBW
- Pixel Count: 320 IC's max
- Pixel Groups: 1, 2, 4, 8, All
- Housing: Black powder-coated metal
- 12–24 V DC IN: 4-pin Phoenix terminal (maximum cable gauge: 2,0525 mm)
- PIXEL OUT: 4-pin Phoenix terminal (maximum cable gauge: 2,0525 mm)
- IP rating: IP20
- Protection class: II
- Operation temperature: -10 °C to +55 °C
- Dimensions: 230 x 45 x 15 mm (LxWxH)
- Weight: 0,16 kg

Front

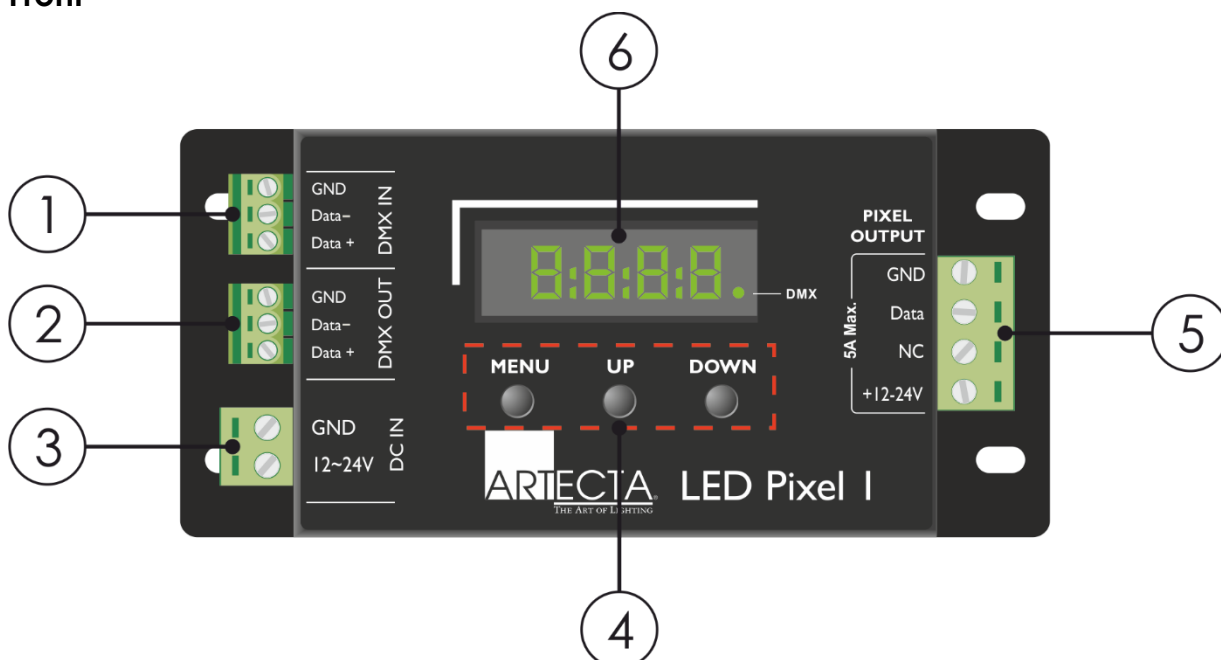

Fig. 01

- 01) DMX IN: Phoenix terminal connector (Ground, Data -, Data +)
 02) DMX OUT: Phoenix terminal connector (Ground, Data -, Data +)
 03) DC IN: Phoenix terminal connector (Ground, 12-24V)
 04) Control buttons (Menu, Up and Down)
 05) PIXEL OUTPUT: (Ground, Data, NC, 12-24V)
 06) OLED display

Installation

Remove all packing materials from the LED Pixel 1. Check if all foam and plastic padding is removed. Connect all cables.

Do not supply power before the whole system is set up and connected properly.

Always disconnect from electric mains power supply before cleaning or servicing.

Damages caused by non-observance are not subject to warranty.

Setup and Operation

Before plugging the device in, always make sure that the power supply matches the product specification voltage.

Control Modes

Setup LED Pixel 1 with Lighting Controller

01) Use a 3-pin XLR cable to connect the LED Pixel 1 to DMX.

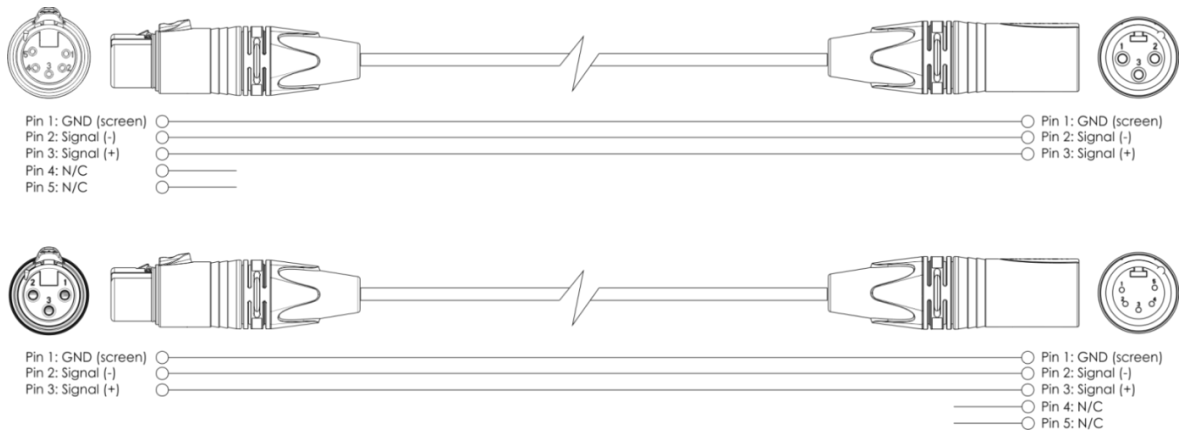

02) Connect a lighting controller to the LED Pixel 1 "in" socket.

03) Connect the LEDstrips to the LED Pixel 1.

04) Supply electric power to LED Pixel 1. Do not supply power before the whole system is set up and connected properly.

Setup LED Pixel 1 with Lighting Controller

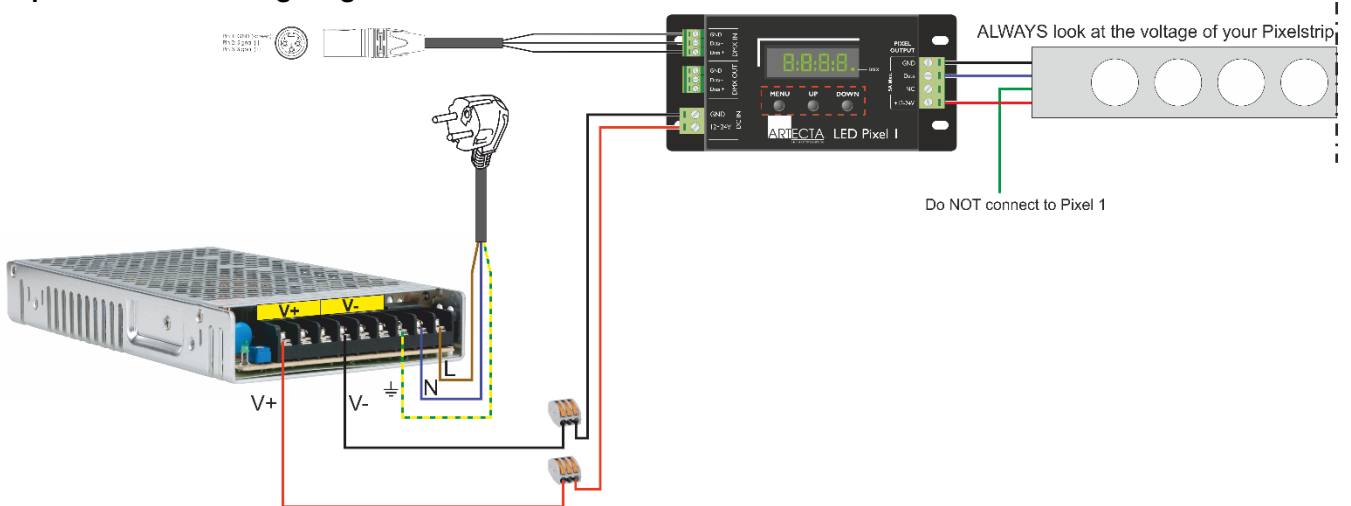

Fig. 03

Note: Link all cables and check the voltage of your Pixelstrip before connecting electric power

Device Linking

You will need a serial data link to run light shows of one or more devices using a DMX-512 controller or to run synchronized shows of two or more devices set to a master/slave operating mode. The combined number of channels required by all the devices on a serial data link determines the number of devices the data link can support.

Important: Devices on a serial data link must be daisy-chained in a single line. To comply with the EIA-485 standard, no more than 30 devices should be connected on one data link. Connecting more than 30 devices on one serial data link without the use of a DMX optically isolated splitter may result in deterioration of the digital DMX signal.



Maximum recommended DMX data link distance: 100 meters
Maximum recommended number of devices on a DMX data link: 30 devices

Control Panel

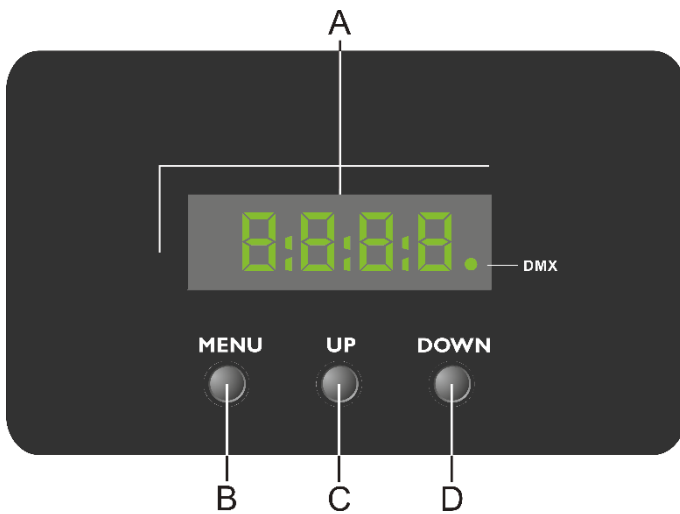

- A) OLED display
- B) MENU button
- C) UP button
- D) DOWN button

Fig. 04

DMX Addressing

The control panel on the front side of the base allows you to assign DMX addresses, which is the first channel with which the LED Dim will respond to the controller.

When using multiple LED Dims, make sure you set the DMX addresses right.

Please, be sure that you do not have any overlapping channels in order to control each LED Dim correctly. If two or more LED Dims are addressed similarly, they will work similarly.

Controlling:

After having addressed all LED Dim devices, you may now start operating these via your lighting controller.

Note: After switching on, the LED Dim will automatically detect whether DMX 512 data is received or not. If it does not, the problem may be:

- The XLR cable from the controller is not connected with the input of the LED Dim.
- The controller is switched off or defective, the cable or connector is defective, or the signal wires are swapped in the input connector.

Note: It is necessary to insert an XLR termination plug (with 120 Ohm) in the last device in order to ensure proper transmission on the DMX data link.

Menu Overview



Main Menu Options

0001

1. DMX Address

9-01

2. Segment grouping (determines the pixel size)

P001

3. Pixel control (defines the total pixels under control)n

5h01

4. Show / Self Test

CH03

5. Channel Mode (Do NOT change this)

1C01

6. Integrated Circuit (Do NOT change this)

Press and hold the MENU button for 2 seconds to enter/exit edit mode for the current menu option.

The bar and dot will flash whenever you are in edit mode.
Press and hold MENU for 2 seconds to enter/exit edit mode.

1. DMX Address

In this menu you can set the DMX starting address.

- 01) While in main menu, press the **UP/DOWN** buttons until the display shows .
- 02) Press and hold down the **MENU** button for 2 seconds to enter.
- 03) Press the **UP/DOWN** buttons to select the DMX starting address. The adjustment range is 001–2048.
- 04) Press the **MENU** button to save changes.

Note:

The DMX address configures the base address for the first color (red) of the first segment, or group of segments (determined by the 9rx setting) of the LED Pixel 1. Successive DMX channels control the remaining colors within the various segments.

When setting the base address, ensure that sufficient channels remain at the upper end to control all of the pixels. For instance, a 5 meter Havana Pixel Strip RGB 24 V ([A0852126](#)) with 50 pixels requires 150 DMX channels, so the base address in such a case cannot be greater than 363 ($513-150=363$).

2. Segment Grouping

In this menu you can set the segment grouping.

- 01) While in main menu, press the **UP/DOWN** buttons until the display shows .
- 02) Press and hold down the **MENU** button for 2 seconds to enter.
- 03) Press the **UP/DOWN** buttons to select the DMX starting address. The adjustment range is gr01-gr02-gr04-gr08-grAL.
- 04) Press the **MENU** button to save changes.

Note:

The segment grouping determines how the various segments of the LED Pixel 1 are matched to the incoming group(s) of three (RGB) DMX channels to form the controllable pixels (i.e. pixel resolution). The options range from the assignment of a set of RGB channels for each individual segment (i.e. a pixel size of 1 segment: 9r01); up to assigning one set of RGB channels to control the whole strip (i.e. up to 320 segments as one pixel, controlled by just 3 channels: 9rAL).

Pixel sections

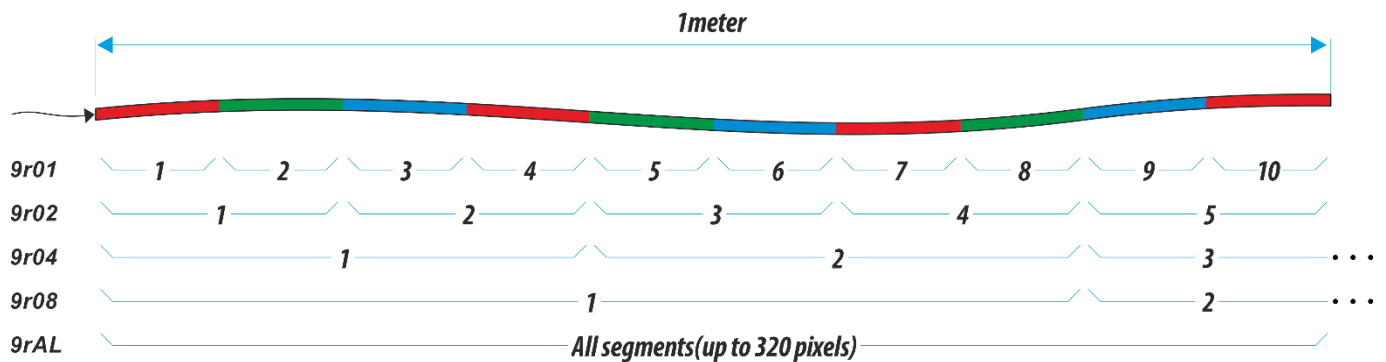

DMX Channels

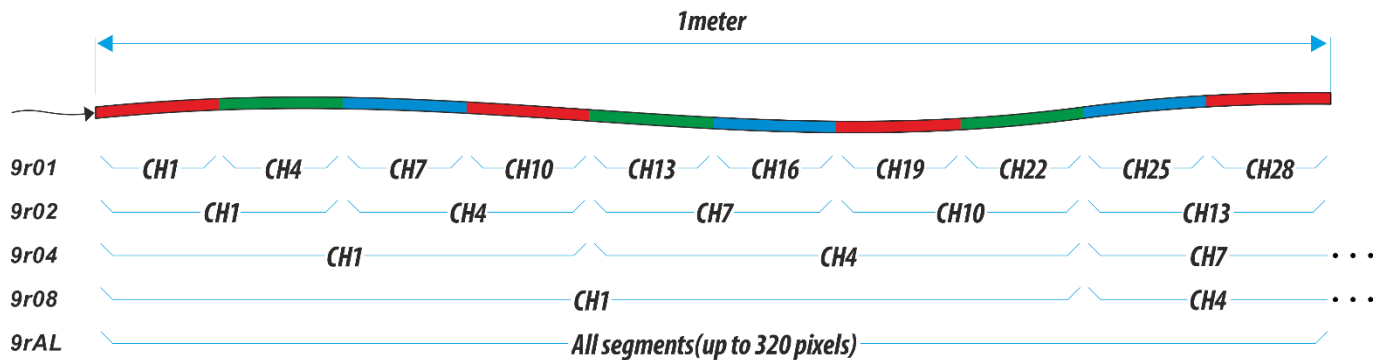

The diagram above shows how the 10 segments within each meter section are affected by the 9rxx option; these settings would be repeated across the remaining length of the Havana Pixel Strip RGB 24 V ([A0852126](#)).

It all depends on the value you have set in the **Pxxx** menu (max. P320).

3. Pixel Range (Pxxx)

- 01) While in main menu, press the **UP/DOWN** buttons until the display shows  .
- 02) Press and hold down the **MENU** button for 2 seconds to enter.
- 03) Press the **UP/DOWN** buttons to select the total number of pixels. The adjustment range is P001-P320.
- 04) Press the **MENU** button to save changes.

This menu defines the total number of pixels you are controlling. This option is interdependent with the 9rxx segment grouping setting, which determines how many segments form each pixel, and how many DMX channels are required to control them.

Without looking at the length of your pixel strip

1 Pixel @ 24V = 6 LEDS = 10 cm

1 Pixel @ 12V = 3 LEDS = ± 5 cm

1 Pixel @ 5V = 1 LED = ± 1,7 cm

Below are some examples for a 24V setup:

gr01

Pixels	Length	Channels
P080	8 m	240 CH
P040	4 m	120 CH
P020	2 m	60 CH
P010	1 m	30 CH

gr02

Pixels	Length	Channels
P080	16 m	240 CH
P040	8 m	120 CH
P020	4 m	60 CH
P010	2 m	30 CH

gr04

Pixels	Length	Channels
P080	32 m	240 CH
P040	16 m	120 CH
P020	8 m	60 CH
P010	4 m	30 CH

gr08

Pixels	Length	Channels
P080	64 m	240 CH
P040	32 m	120 CH
P020	16 m	60 CH
P010	8 m	30 CH

When the strip you've selected doesn't fully light up, the problem may be a wrong value you've selected for Pxxx.

Example:

A 5-meter Havana Pixel Strip RGB 24 V ([A0852126](#)) with 50 pixels requires 150 DMX channels.

When you set the value to P005, only the first 50 cm (at a set value of **gr01**) will light up and not the entire strip.

When you set the value to P005, only the first 100 cm (at a set value of **gr02**) will light up and not the entire strip.

There are no major issues with setting the Pxxx value too high for a given number of pixels. The only minor issue caused by setting the Pxxx value higher than the actual number of pixels becomes apparent when the show/self-tests Sh03 and Sh04 are performed.

In Sh03, the scrolling pixel will disappear at the upper end (while it visits non-existent segments) before running back down the length of the strip.

In Sh04, the halfway split in the strip will move toward the upper end.

Option 1

Set values: gr01 and P050

The Sh03 show program will run to the end of the strip and then reverse in a different color.

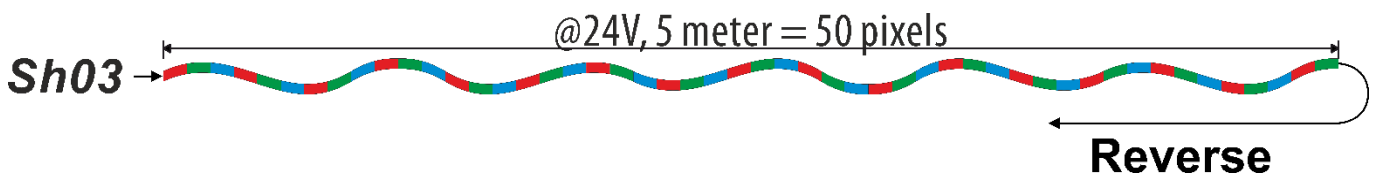

Option 2

Set values: gr01 and P075

The Sh03 show program will run to the end of the 5m strip and keep on running for 25 pixels that are non-existent. Only when reaching the set value of P075 will the show reverse.

When reaching the 50th pixel the program will become visible again.

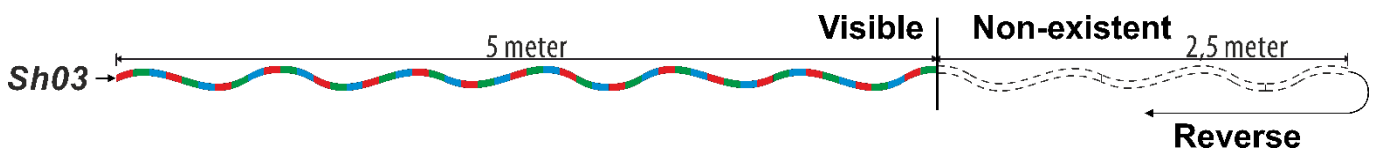

Option 3

Set values: gr01 and P100

The Sh03 show program will run to the end of the strip and keep on running for 50 pixels that are non-existent. Only when reaching the set value of P100 will the show return.

That means that the entire strip will momentarily appear to black out. However this is not true. The sh03 show will keep running from the non-existent 51th to 100th pixel and then reverse.

When reaching the 50th pixel the program will become visible again.

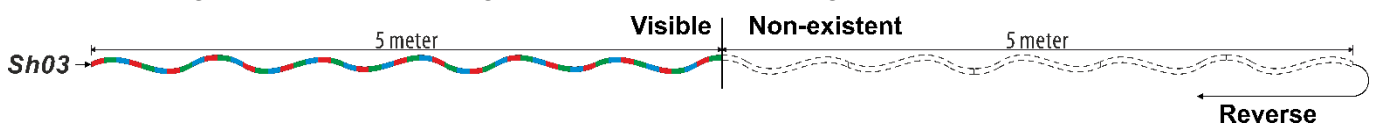

Option 4

Set values: gr01 and P025

When the value is set too low, the pixels which lie beyond the stated limit will not illuminate.

So when using a 5 meter strip with 50 pixels and you set it to P025, will result in half of the strip never lighting up.

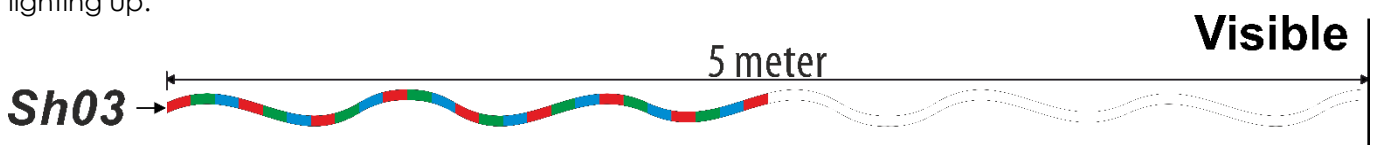

4. Show / Self-Test MODE (Shxx)

This menu option provides self-test routines designed to help check for stuck or failed emitters within an installation. No DMX input is required to run these tests.

- 01) Configure the required segment grouping and pixel range settings for the installed Havana Pixel Strip RGB 24 V ([A0852126](#)).
- 02) Use the **UP/DOWN** buttons repeatedly until the display shows Shxx (where xx is a value between 01 and 04).
- 03) Press and hold the **MENU** button for roughly two seconds until the bar and dot on the left side of the display start flashing .
- 04) Use the UP/DOWN buttons to choose any of the four test sequences:

Sh01	Shows a rapid sequential strobing through all red, green and blue emitters
Sh02	Slowly fades between all red, green and blue emitters
Sh03	Shows a band of pixels which scroll from begin to end and back again, alternately using the red, green and blue emitters*
Sh04	Shows two separate slow fades in each half of the strip, alternately using the red, green and blue emitters*

* The exact manner in which the Pixel strip responds to these tests is determined by the 9xx and Pxx menu settings, see page 10-12.

- 05) Press and hold the MENU button for roughly two seconds until the bar and dot on the left side of the display stop flashing.

Note: The last state of the test pattern will remain until either a DMX input is applied or the power input is cycled.

6. Channel Working Mode:

CH01 for single white

CH02 for DW (CW+WW)

CH03 for RGB

CH04 for RGBW (Clear lighting Flex Pixel Tube, RGBW, 6 pixels control per meter)

Note:

Currently Highlite does not sell any RGBW LEDstrip with 24V.

7. Select different ICs

Your Pixel Driver 1 can control many different flex pixel tapes, but on the market, there are many manufactures who use different ICs.

IC01:UCS2904 (Clear lighting Flex Pixel Tube, RGBW, 8 pixels control per meter)

IC02:WS2911, UCS2903

IC03:WS2812

IC04:TM1812

IC05:WS2801

IC06:APA101

IC08

Note: All of our currently available LEDstrips have to be set to IC08

DMX Channels

Depending on the values set in **grxx** and **Pxxx**, the DMX channels will be set.
 The maximum number of DMX channels is 320 channels when set to P0320 and when using multiple pixelstrips.

Example:

5 meter Havana Pixel Strip RGB 24 V ([A0852126](#)) with all 50 pixels used.

DMX Channels

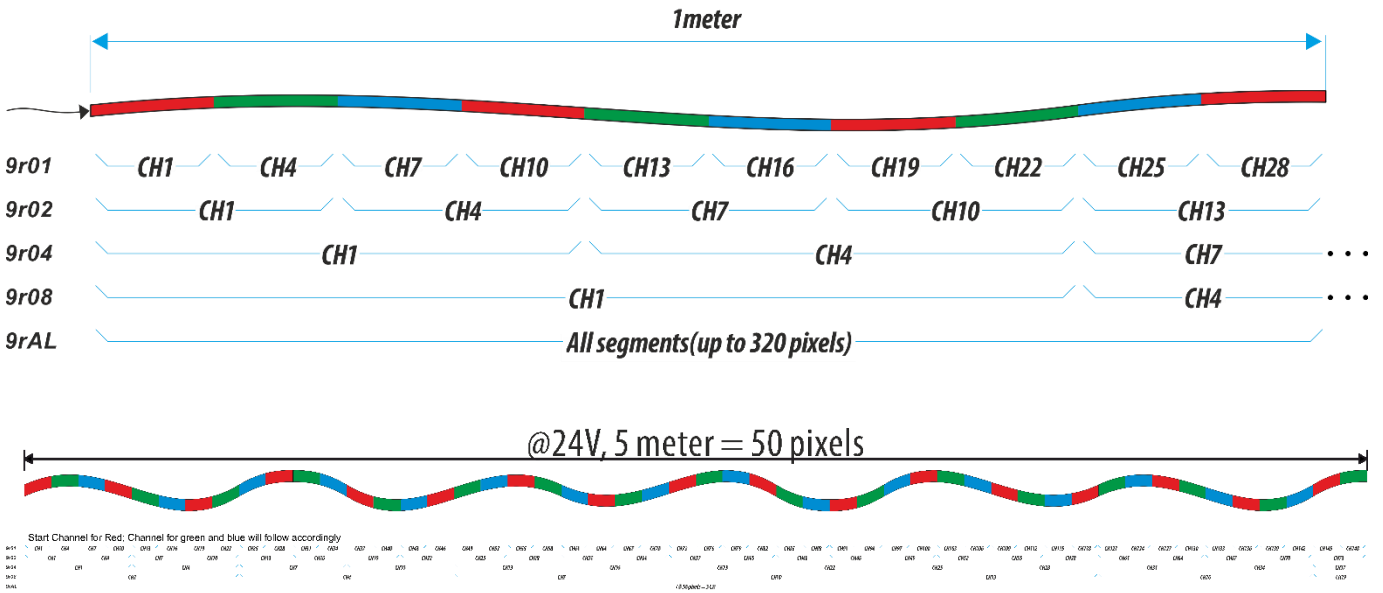

150 channels (RGB)

Set to gr01 and P050

Channel 1 – Section 1 (Pixel 1=10 cm) Red

0–255 Gradual adjustment Red, from dark to brightest

Channel 2 – Section 1 (Pixel 1-2=10 cm) Green

0–255 Gradual adjustment Green, from dark to brightest

Channel 3 – Section 1 (Pixel 1-2=10 cm) Blue

0–255 Gradual adjustment Blue, from dark to brightest

Channel 4 – Section 2 (Pixel 3-4=10 cm) Red

0–255 Gradual adjustment Red, from dark to brightest

Channel 5 – Section 2 (Pixel 3-4=10 cm) Green

0–255 Gradual adjustment Green, from dark to brightest

Channel 6 – Section 2 (Pixel 3-4=10 cm) Blue

0–255 Gradual adjustment Blue, from dark to brightest

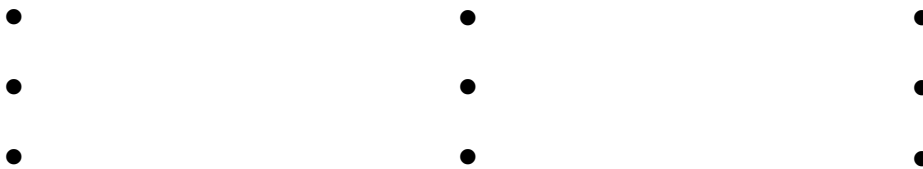
**Channel 142 – Section 23 (Pixel 48=10 cm) Red**

0–255 Gradual adjustment Red, from dark to brightest

Channel 143 – Section 23 (Pixel 48=10 cm) Green

0–255 Gradual adjustment Green, from dark to brightest

Channel 144 – Section 23 (Pixel 48=10 cm) Blue

0–255 Gradual adjustment Blue, from dark to brightest

Channel 145 – Section 24 (Pixel 49=10 cm) Red

0–255 Gradual adjustment Red, from dark to brightest

Channel 146 – Section 24 (Pixel 49=10 cm) Green

0–255 Gradual adjustment Green, from dark to brightest

Channel 147 – Section 24 (Pixel 49=10 cm) Blue

0–255 Gradual adjustment Blue, from dark to brightest

Channel 148 – Section 25 (Pixel 50=10 cm) Red

0–255 Gradual adjustment Red, from dark to brightest

Channel 149 – Section 25 (Pixel 50=10 cm) Green

0–255 Gradual adjustment Green, from dark to brightest

Channel 150 – Section 25 (Pixel 50=10 cm) Blue

0–255 Gradual adjustment Blue, from dark to brightest

75 channels (RGB)

Set to gr02 and P050

Channel 1 – Section 1 (Pixel 1-2=20 cm) Red

0–255 Gradual adjustment Red, from dark to brightest

Channel 2 – Section 1 (Pixel 1-2=20 cm) Green

0–255 Gradual adjustment Green, from dark to brightest

Channel 3 – Section 1 (Pixel 1-2=20 cm) Blue

0–255 Gradual adjustment Blue, from dark to brightest

Channel 4 – Section 2 (Pixel 3-4=20 cm) Red

0–255 Gradual adjustment Red, from dark to brightest

Channel 5 – Section 2 (Pixel 3-4=20 cm) Green

0–255 Gradual adjustment Green, from dark to brightest

Channel 6 – Section 2 (Pixel 3-4=20 cm) Blue

0–255 Gradual adjustment Blue, from dark to brightest

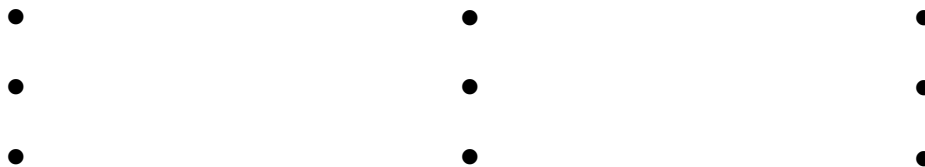
**Channel 67 – Section 23 (Pixel 45-46=20 cm) Red**

0–255 Gradual adjustment Red, from dark to brightest

Channel 68 – Section 23 (Pixel 45-46=20 cm) Green

0–255 Gradual adjustment Green, from dark to brightest

Channel 69 – Section 23 (Pixel 45-46=20 cm) Blue

0–255 Gradual adjustment Blue, from dark to brightest

Channel 70 – Section 24 (Pixel 47-48=20 cm) Red

0–255 Gradual adjustment Red, from dark to brightest

Channel 71 – Section 24 (Pixel 47-48=20 cm) Green

0–255 Gradual adjustment Green, from dark to brightest

Channel 72 – Section 24 (Pixel 47-48=20 cm) Blue

0–255 Gradual adjustment Blue, from dark to brightest

Channel 73 – Section 25 (Pixel 49-50=20 cm) Red

0–255 Gradual adjustment Red, from dark to brightest

Channel 74 – Section 25 (Pixel 49-50=20 cm) Green

0–255 Gradual adjustment Green, from dark to brightest

Channel 75 – Section 25 (Pixel 49-50=20 cm) Blue

0–255 Gradual adjustment Blue, from dark to brightest

39 channels (RGB)

Set to gr04 and P050

Channel 1 – Section 1 (Pixel 1-4=40 cm) Red

0–255 Gradual adjustment Red, from dark to brightest

Channel 2 – Section 1 (Pixel 1-4=40 cm) Green

0–255 Gradual adjustment Green, from dark to brightest

Channel 3 – Section 1 (Pixel 1-4=40 cm) Blue

0–255 Gradual adjustment Blue, from dark to brightest

Channel 4 – Section 2 (Pixel 5-8=40 cm) Red

0–255 Gradual adjustment Red, from dark to brightest

Channel 5 – Section 2 (Pixel 5-8=40 cm) Green

0–255 Gradual adjustment Green, from dark to brightest

Channel 6 – Section 2 (Pixel 5-8=40 cm) Blue

0–255 Gradual adjustment Blue, from dark to brightest

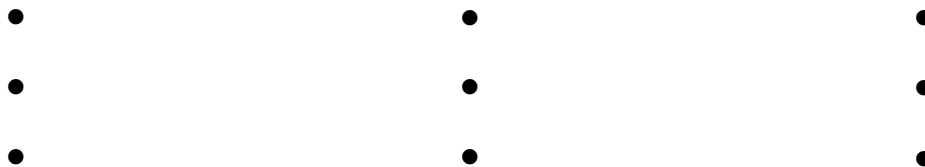
**Channel 31 – Section 11 (Pixel 41-44=40 cm) Red**

0–255 Gradual adjustment Red, from dark to brightest

Channel 32 – Section 11 (Pixel 41-44=40 cm) Green

0–255 Gradual adjustment Green, from dark to brightest

Channel 33 – Section 11 (Pixel 41-44=40 cm) Blue

0–255 Gradual adjustment Blue, from dark to brightest

Channel 34 – Section 12 (Pixel 45-48=40 cm) Red

0–255 Gradual adjustment Red, from dark to brightest

Channel 35 – Section 12 (Pixel 45-48=40 cm) Green

0–255 Gradual adjustment Green, from dark to brightest

Channel 36 – Section 12 (Pixel 45-48=40 cm) Blue

0–255 Gradual adjustment Blue, from dark to brightest

Channel 37 – Section 13 (Pixel 49-50=20 cm) Red

0–255 Gradual adjustment Red, from dark to brightest

Channel 38 – Section 13 (Pixel 49-50=20 cm) Green

0–255 Gradual adjustment Green, from dark to brightest

Channel 39 – Section 13 (Pixel 49-50=20 cm) Blue

0–255 Gradual adjustment Blue, from dark to brightest

21 channels (RGB)

Set to gr08 and P050

Channel 1 – Section 1 (Pixel 1-8=80 cm) Red

0-255 Gradual adjustment Red, from dark to brightest

Channel 2 – Section 1 (Pixel 1-8=80 cm) Green

0-255 Gradual adjustment Green, from dark to brightest

Channel 3 – Section 1 (Pixel 1-8=80 cm) Blue

0-255 Gradual adjustment Blue, from dark to brightest

Channel 4 – Section 2 (Pixel 9-16=80 cm) Red

0-255 Gradual adjustment Red, from dark to brightest

Channel 5 – Section 2 (Pixel 9-16=80 cm) Green

0-255 Gradual adjustment Green, from dark to brightest

Channel 6 – Section 2 (Pixel 9-16=80 cm) Blue

0-255 Gradual adjustment Blue, from dark to brightest

Channel 7 – Section 3 (Pixel 17-24=80 cm) Red

0-255 Gradual adjustment Red, from dark to brightest

Channel 8 – Section 3 (Pixel 17-24=80 cm) Green

0-255 Gradual adjustment Green, from dark to brightest

Channel 9 – Section 3 (Pixel 17-24=80 cm) Blue

0-255 Gradual adjustment Blue, from dark to brightest

Channel 10 – Section 4 (Pixel 25-32=80 cm) Red

0-255 Gradual adjustment Red, from dark to brightest

Channel 11 – Section 4 (Pixel 25-32=80 cm) Green

0-255 Gradual adjustment Green, from dark to brightest

Channel 12 – Section 4 (Pixel 25-32=80 cm) Blue

0-255 Gradual adjustment Blue, from dark to brightest

Channel 13 – Section 5 (Pixel 33-40=80 cm) Red

0-255 Gradual adjustment Red, from dark to brightest

Channel 14 – Section 5 (Pixel 33-40=80 cm) Green

0-255 Gradual adjustment Green, from dark to brightest

Channel 15 – Section 5 (Pixel 33-40=80 cm) Blue

0-255 Gradual adjustment Blue, from dark to brightest

Channel 16 – Section 6 (Pixel 41-48=80 cm) Red

0-255 Gradual adjustment Red, from dark to brightest

Channel 17 – Section 6 (Pixel 41-48=80 cm) Green

0-255 Gradual adjustment Green, from dark to brightest

Channel 18 – Section 6 (Pixel 41-48=80 cm) Blue

0-255 Gradual adjustment Blue, from dark to brightest

Channel 19 – Section 7 (Pixel 49-50=20 cm) Red

0–255 Gradual adjustment Red, from dark to brightest

Channel 20 – Section 7 (Pixel 49-50=20 cm) Green

0–255 Gradual adjustment Green, from dark to brightest

Channel 21 – Section 7 (Pixel 49-50=20 cm) Blue

0–255 Gradual adjustment Blue, from dark to brightest

3 channels (RGB)

Set to grAL and P050

Channel 1 – Section 1 (Pixel 1-50=500 cm) Red

0–255 Gradual adjustment Red, from dark to brightest

Channel 2 – Section 1 (Pixel 1-50=500 cm) Green

0–255 Gradual adjustment Green, from dark to brightest

Channel 3 – Section 1 (Pixel 1-50=500 cm) Blue

0–255 Gradual adjustment Blue, from dark to brightest

Maintenance

The LED Pixel 1 requires almost no maintenance. However, you should keep the device clean. Disconnect the mains power supply and then wipe the cover with a damp cloth. Do not immerse in liquid. Do not use alcohol or solvents.

Keep connections clean. Disconnect electric power and then wipe the connections with a damp cloth. Make sure connections are thoroughly dry before linking equipment or supplying electric power.

The operator has to make sure that safety-related and machine-technical installations are to be inspected by an expert after every year in the course of an acceptance test.

The operator has to make sure that safety-related and machine-technical installations are to be inspected by a skilled person once a year.

The following points have to be considered during the inspection:

- 01) All screws used for installing the device or parts of the device have to be tightly connected and must not be corroded.
- 02) There may not be any deformations on housings, fixations and installation spots.
- 03) Mechanically moving parts like axles, eyes and others may not show any traces of wearing.
- 04) The electric power supply cables must not show any damages or material fatigue.

Troubleshooting

No Light

If the device does not operate properly, refer servicing to a technician.

Suspect four potential problem areas as: the power supply, the internal fuse, the LED Pixel 1, the LEDs.

- 01) Power supply. Check if the device is plugged into an appropriate power supply.
- 02) The internal fuse. Return the LED Pixel 1 to your Artecta dealer.
- 03) The LED Pixel 1. Return the LED Pixel 1 to your Artecta dealer.
- 04) The LEDs. Refer to the user manual of the LEDs for more information.
- 05) If all appears to be O.K., plug the device in again.
- 06) If you are unable to determine the cause of the problem, do not open the LED Pixel 1, as this may damage the device and the warranty will become void.
- 07) Return the device to your Artecta dealer.

No Response to DMX

- 01) Check the DMX setting. Make sure that DMX addresses are correct.
- 02) Check the DMX cable: Unplug the device; change the DMX cable; then reconnect to electrical power. Try your DMX control again.
- 03) Determine whether the controller or the LED Pixel 1 is at fault. Does the controller operate properly with other DMX products? If not, take the controller in for repair. If it does, take the DMX cable and the LED Pixel 1 to a qualified technician.

Problem	Probable cause(s)	Remedy
One or more device does not function at all	No power to the device	<ul style="list-style-type: none"> • Check if power is switched on and cables are plugged in
	Internal fuse blown	<ul style="list-style-type: none"> • Return the device to your Showtec dealer
Devices reset correctly, but all respond erratically or not at all to the controller	The controller is not connected	<ul style="list-style-type: none"> • Connect controller
	3-pin XLR Out of the controller does not match XLR In of the first device on the link (i.e. signal is reversed)	<ul style="list-style-type: none"> • Install a phase reversing cable between the controller and the first device on the link
Devices start correctly, but some respond erratically or not at all to the controller	Poor data quality	<ul style="list-style-type: none"> • Check data quality. If much lower than 100 percent, the problem may be a bad data link connection, poor quality or broken cables, missing termination plug, or a defective device disturbing the link
	Bad data link connection	<ul style="list-style-type: none"> • Inspect connections and cables. Correct poor connections. Repair or replace damaged cables
	Data link not terminated with 120 Ohm termination plug	<ul style="list-style-type: none"> • Insert termination plug in output jack of the last device on the link
	Incorrect addressing of the devices	<ul style="list-style-type: none"> • Check address setting
	One of the devices is defective and disturbs data transmission on the link	<ul style="list-style-type: none"> • Bypass one device at a time until normal operation is regained: unplug both connectors and connect them directly together • Have the defective device serviced by a qualified technician
	3-pin XLR Out on the devices does not match (pins 2 and 3 reversed)	<ul style="list-style-type: none"> • Install a phase-reversing cable between the devices or swap pin 2 and 3 in the device, that behaves erratically
No light or LEDs cut out intermittently	Device is too hot	<ul style="list-style-type: none"> • Allow the device to cool down • Turn up the air conditioning
	LEDs damaged	<ul style="list-style-type: none"> • Refer to the user manual of the LEDs
	The power supply settings do not match local AC voltage and frequency	<ul style="list-style-type: none"> • Disconnect device. Check settings and correct if necessary

Product Specifications

Model:	Arctecta LED Pixel 1
Power supply:	12-24V DC
Load @ 12 V:	max. 6 A/channel (15 A total/180 W)
Load @ 24 V:	max. 6 A/channel (15 A total/360 W)
Housing:	Black powder-coated metal
DMX connections:	3-pin XLR/RJ45 IN/OUT
12-24V DC IN:	4-pin Phoenix terminal (maximum cable gauge: 2,0525 mm)
PWM OUT:	4-pin Phoenix terminal (maximum cable gauge: 2,0525 mm)
Pixel Control:	1CH W 2CH Dynamic White 3CH RGB 4CH RGBW
Input Protocol:	DMX-512
Output Protocol:	SPI
SPI control:	UCS2903, UCS2904, WS2801, WS2812, WS2911, TM1812, APA101, P943F
Pixel Count:	320 IC's max (Pxxx)
Pixel Groups:	1, 2, 4, 8, All (Grxx)
IP rating:	IP20
Protection class:	II
Operation temperature:	-10 °C to +55 °C
Storage temperature:	-20 °C to +70 °C
Dimensions:	115 x 54 x 24 mm (LxWxH)
Weight:	0,16 kg

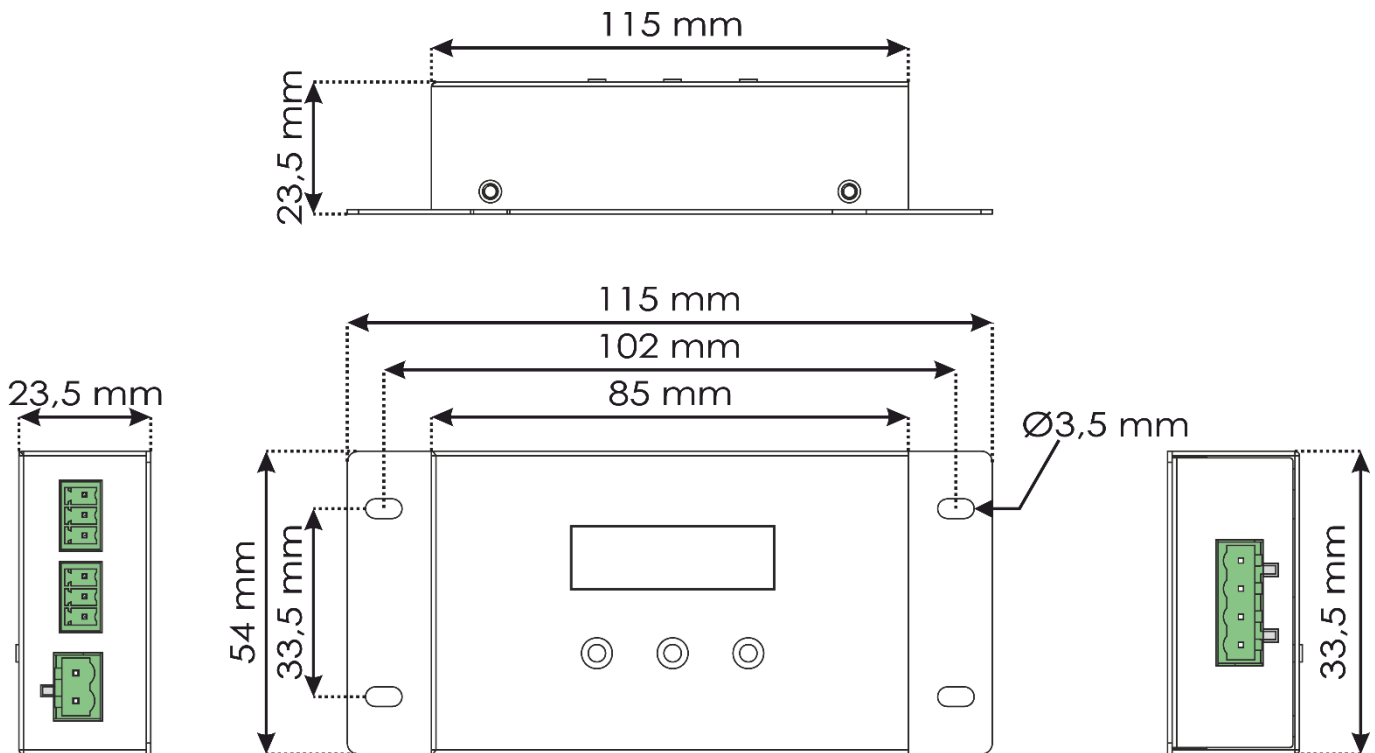

Design and product specifications are subject to change without prior notice.



Website: <https://www.artecta-lights.com/>
Email: service@highlite.com



©2021 Artecta