

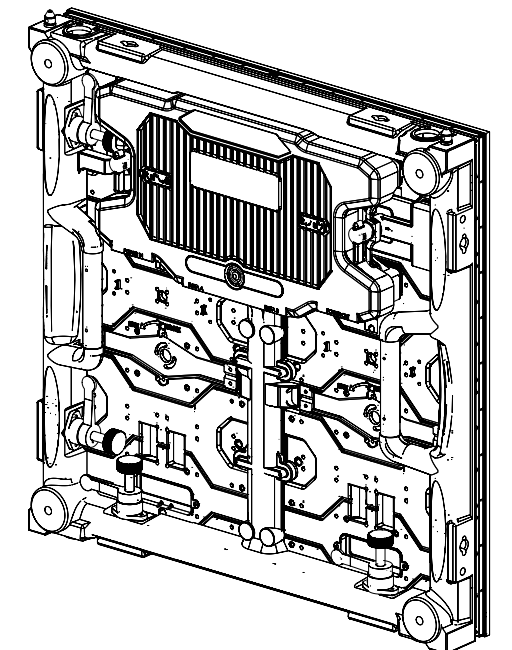

PS-3.9 Blue Line 50x50cm

Pixel Pitch:	3,91 mm
Brightness Level:	5000 nits
Transparency:	0%
Refresh rate:	3840Hz
Module Resolution:	64 x 128 px
Cabinet Resolution:	128 x 128 px
Viewing angle:	160° x 155° (H x V)
Control system:	Novastar A5s PLUS
Input Voltage:	100-240 VAC 50-60Hz
Max Power Consumption:	150 W/panel
Average Power Consumption:	50 W/panel
IP Rating:	IP54 Rear/ IP65 Front
Data connection:	ProCat
Power connection:	Power Pro True
Cooling:	Convection
Maintenance:	Front, Rear
Mechanical connection:	Fast Lock System
Maximum rigging height:	Hor: 18 Cabinets / Ver: 18 Cabinets
Module size:	250 x 500 mm (W x H)
Cabinet size:	500 x 500 x 66 mm (W x H x D)
Cabinet weight:	8,5 Kg
Housing material:	Magnesium Die-cast
Curved angle:	N/A
Operating Temperature:	-20°C ~ +45°C
Certification:	CE / EMC / UKCA

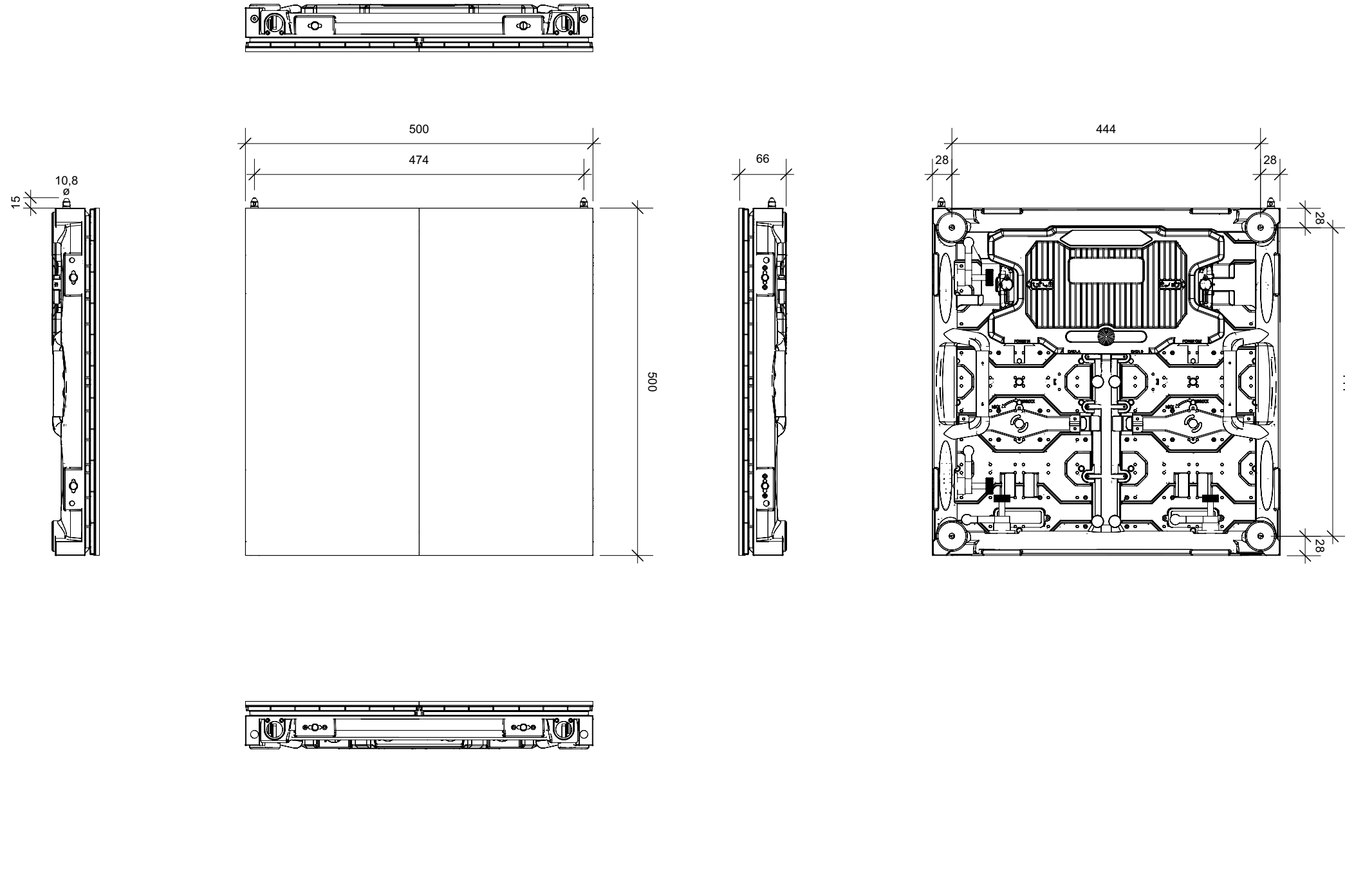

Ordercode : 101770	Item : PS-3.9 Blue Line 50x50cm	Version: 1
 DMT DAP-Audio Infinity Showtec Arctea	Drawn by: MVG	Short Description :
	Creation date: 09/03/2022	Specsheet
	Units: mm	Description :
	Scale: 1:7	
Highlite International BV, Vestastraat 2, 6468 EX Kerkrade, tel: +31 (0)45 5667700, www.highlite.nl		